

1. Wykonanie otworów w ścianie

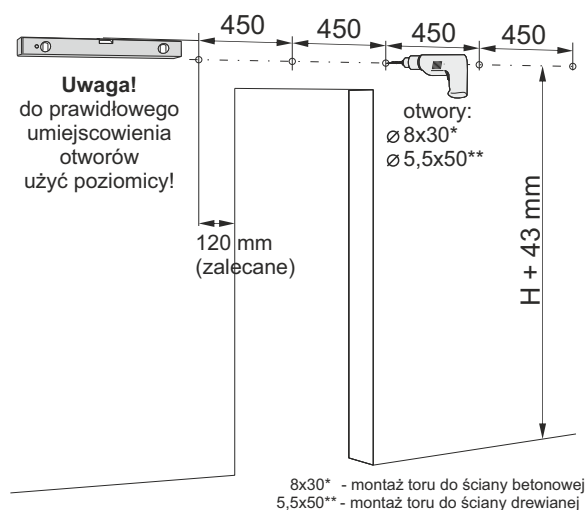

2. Montaż odbojów w torze

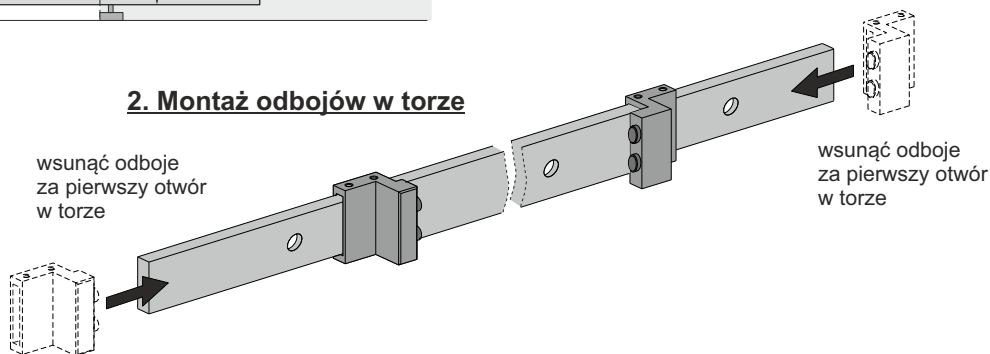

3. Montaż torów do ściany

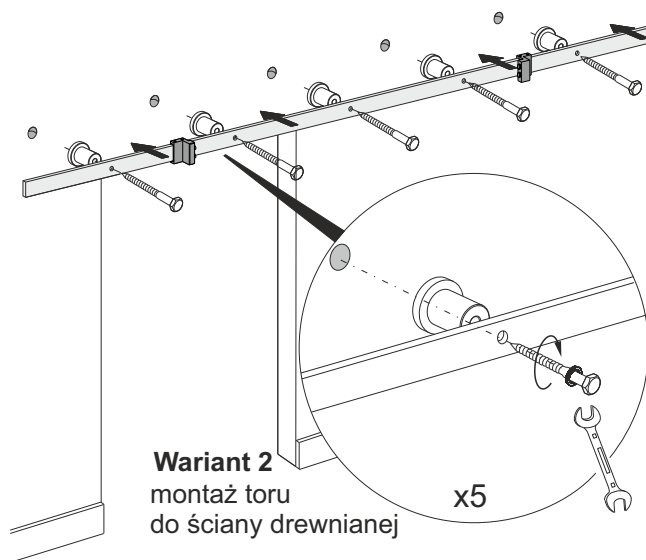
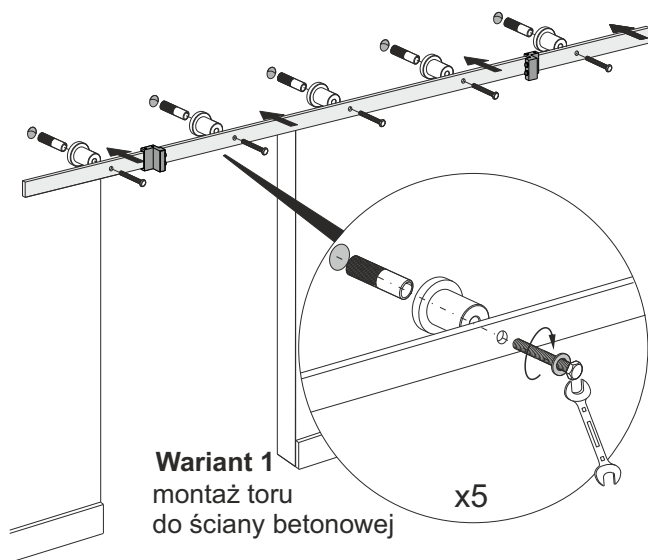

ELEMENTY DODATKOWE

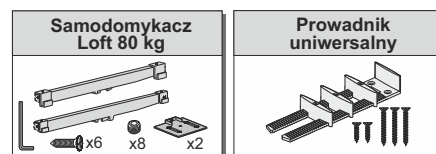

ELEMENTY SKŁADOWE



4. Montaż wózków

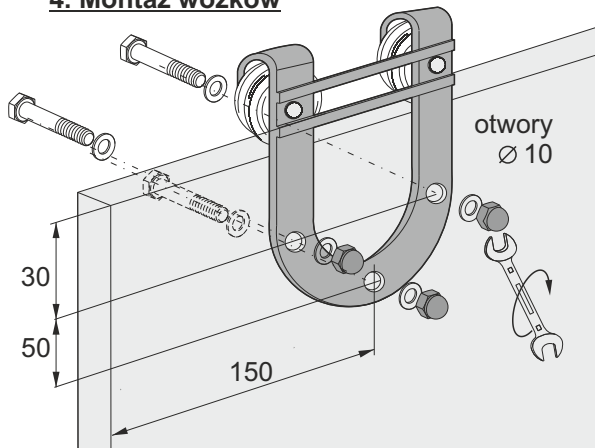

5. Montaż odbojników w drzwiach

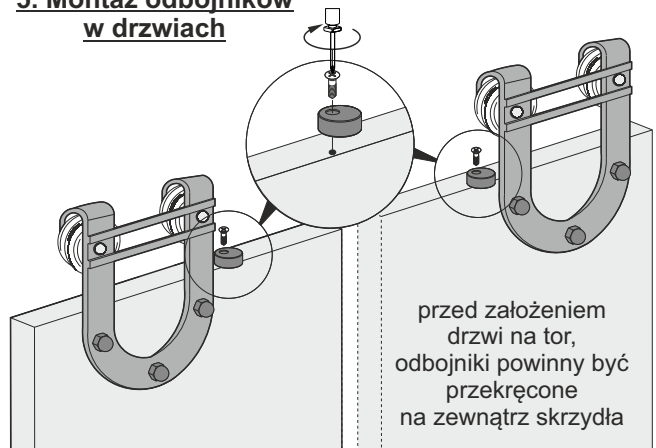

6. Montaż drzwi

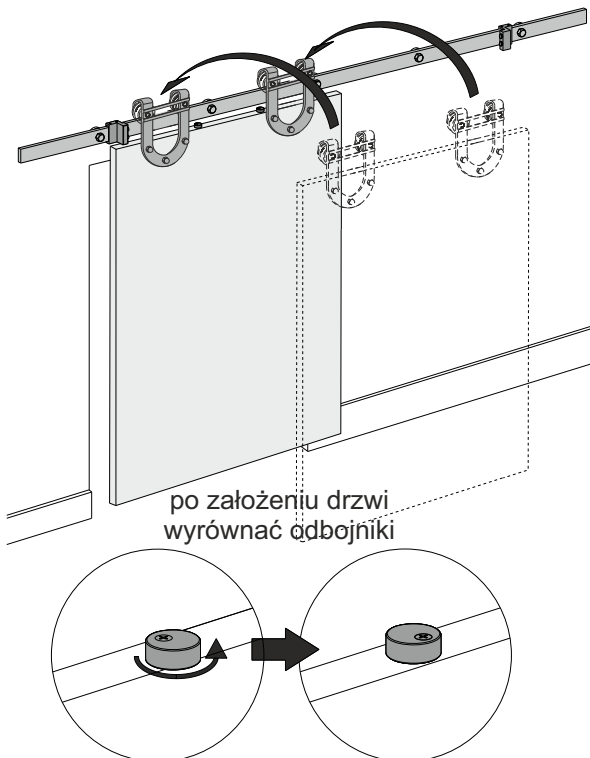

7. Montaż prowadnika

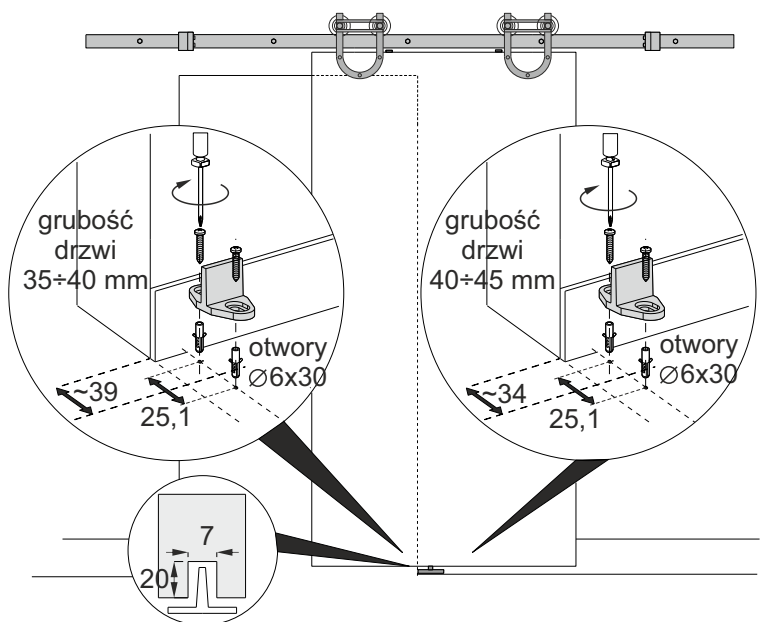

8. Regulacja położenia odbojników na torze

