

COMPACT is an **exclusive** system
for free-standing wardrobes





The main advantage of this system is its compact modern appearance blending perfectly with today's trends: barely visible tracks, and a vast array of 18 mm board variety.

What most distinguishes COMPACT from other systems is soft-closers hidden within the top track. Track masking profiles that wrap around the carcass front – removing the need for edging on the top and bottom of the carcass.

Utilising our Finishing profile, which sits flush, also masks the screws securing the lower track. This gives the impression that all 3 lower profile elements are 1!

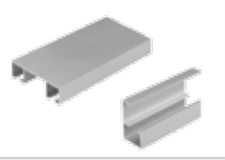
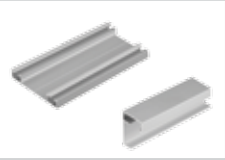
Top guides and bottom carriages are quipped with locking mechanisms, this greatly improves the ease of door installation and removal. Innovatively, the bottom carriages sweep the track just ahead of the rollers. This ensures a silent glide and extends carriage lifespan.

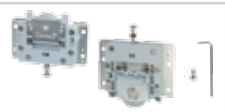
Basic components of system COMPACT

PRODUCT	NAME	INDEX	COLOUR	LENGTH (mm)
	Top track Compact / Top track masking profile	04395 / 04397	SILVER	1700
		04396 / 04398		2350
		04578 / 04580		3000
		04579 / 04581		6000
	Bottom track Compact / Bottom track masking profile	04393 / 04582	SILVER	1700
		04394 / 04583		2350
		04576 / 04584		3000
		04577 / 04585		6000
	Finishing profile for bottom track Cleft	04072	SILVER	1700
		04073		2350
		04074		3000
		04076		6000
	Set Compact (1 door) - 2x bottom carriage Compact - 2x top guide Compact - 1x allen key 2 mm - 16x screws Ø4x14	10215	-	-
	Soft-close Compact (set 2 pcs)	20347	-	-

COMPACT



The main advantages of system COMPACT are:

- Soft-closers hidden within the top track
- Track masking profiles that wrap around the carcass front
- Bottom carriages containing brush that cleans the track ahead of the rollers
- Barely visible top and bottom tracks

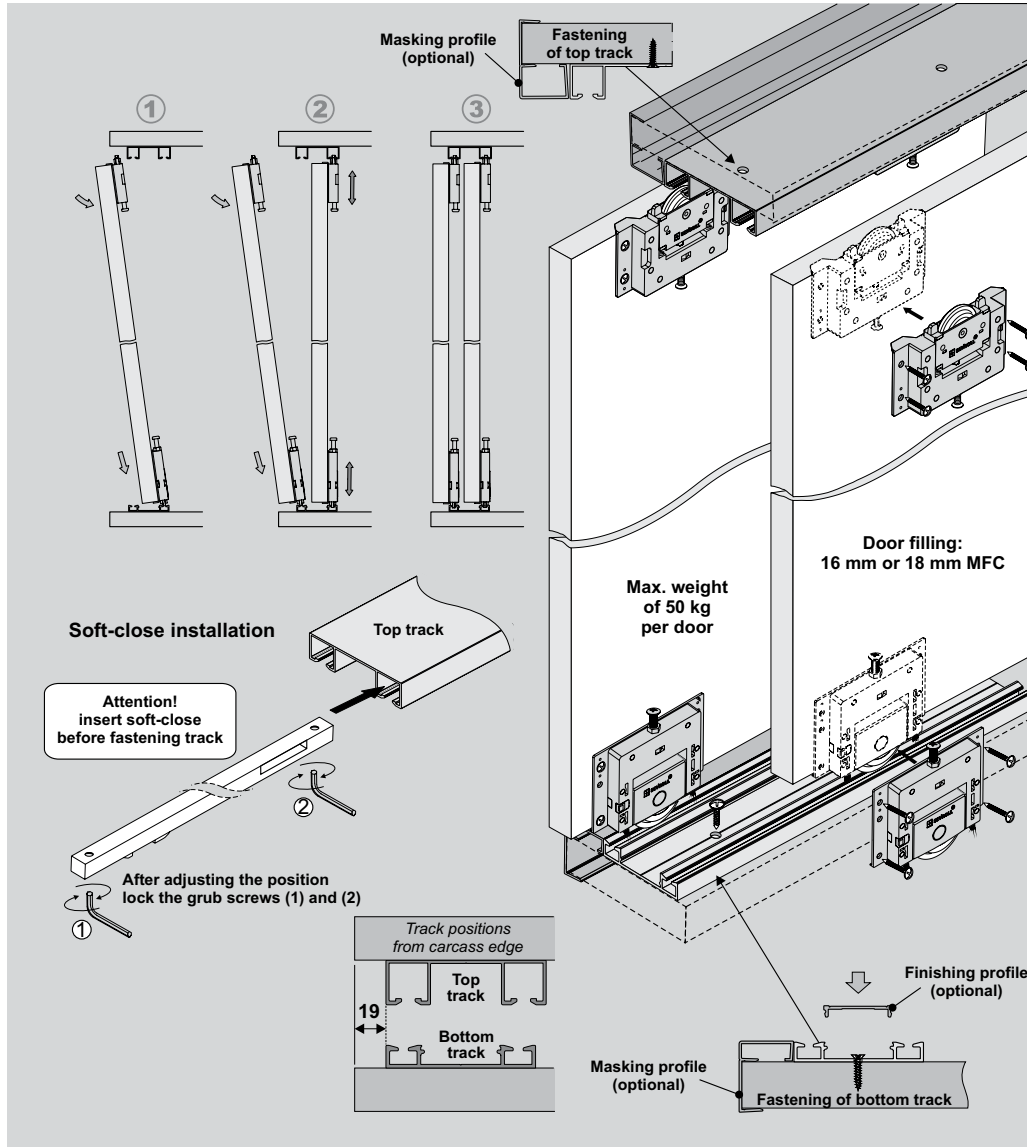

COMPONENTS

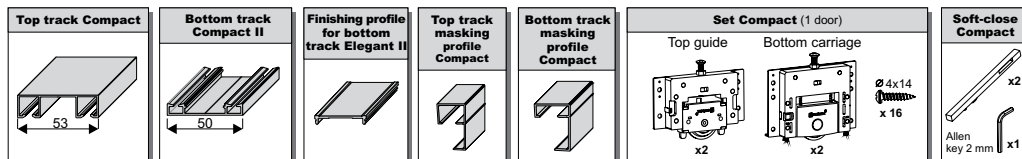

Length: 1.7 m, 2.35 m, 3.0 m, 6.0 m

1. Door installation

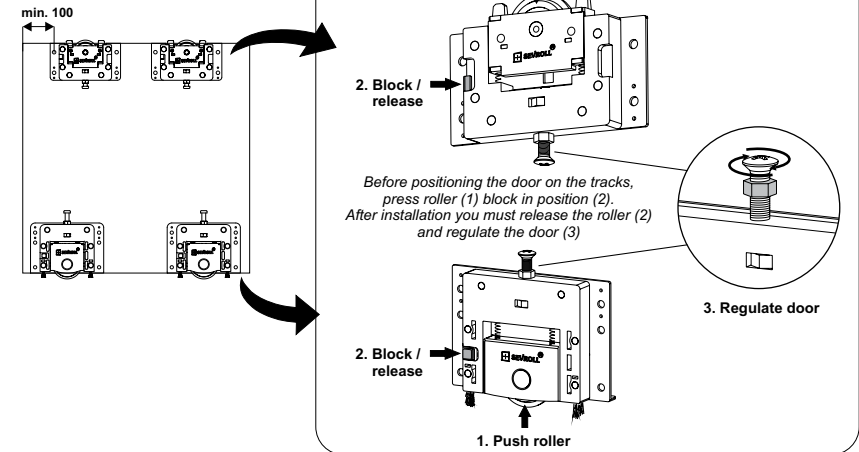

Dimensions of opening

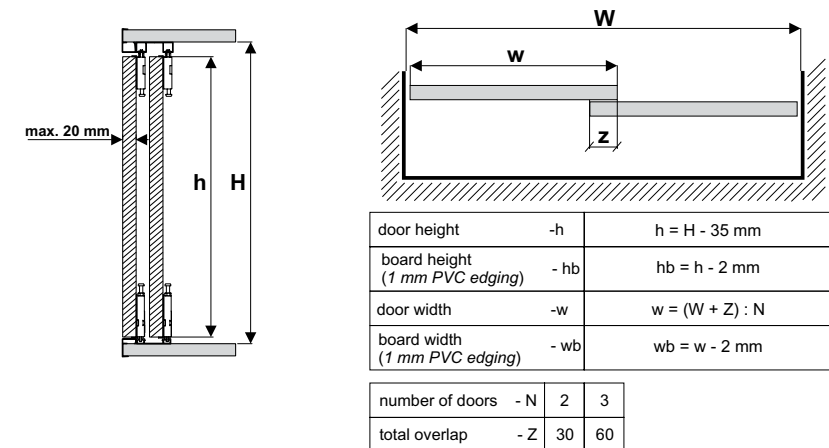

Warning! When using masking profiles carcass sides should protrude a min. of 3 mm

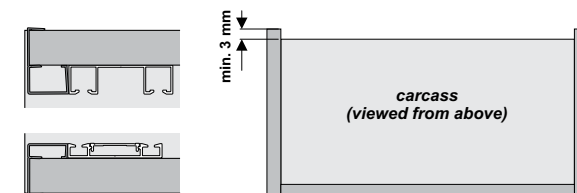

ATTENTION! Remove protective film from aluminium elements (handles, tracks, connectors, etc.) prior to cutting them to the desired size. Film removal will reveal quality issues (eg. scratches)