

1. Hole positioning on wall

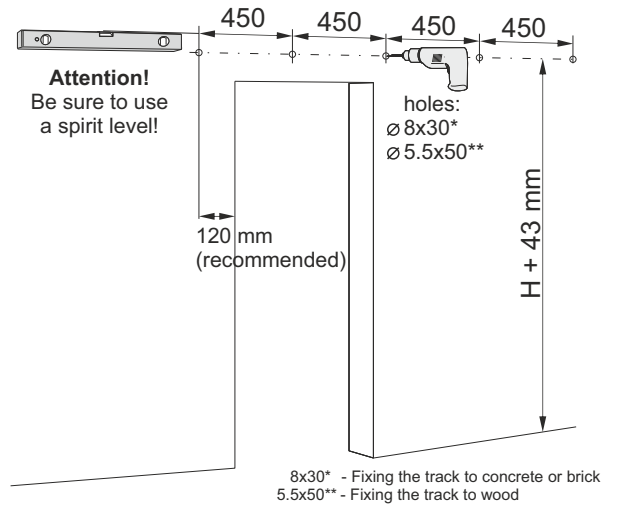

2. Installation of stopper with track

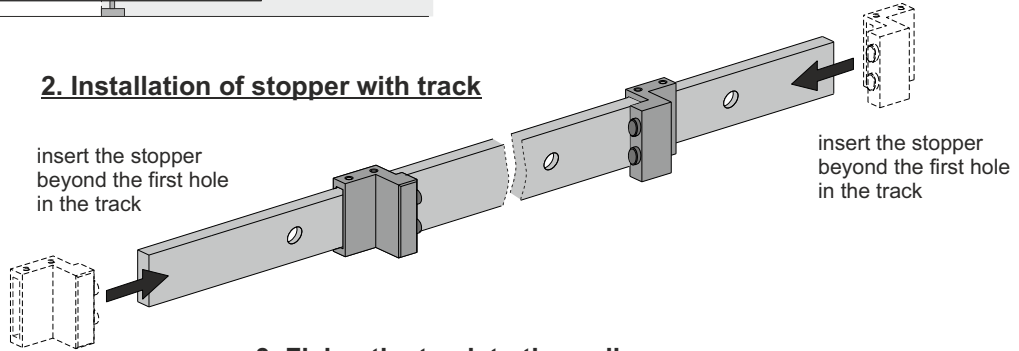

3. Fixing the track to the wall

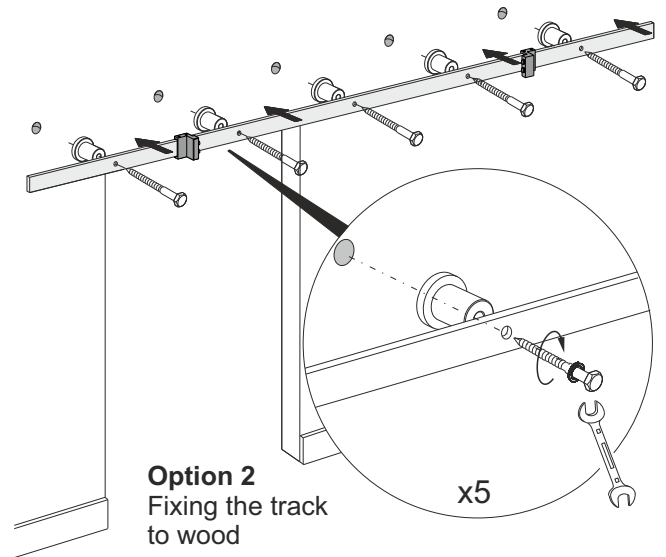
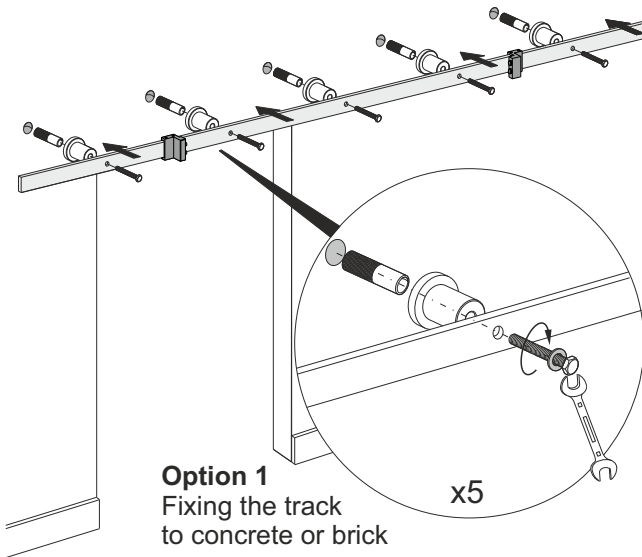

ADDITIONAL COMPONENTS

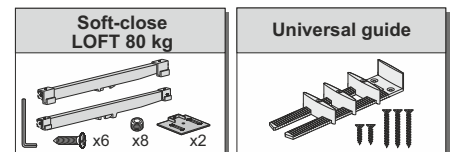

COMPONENTS

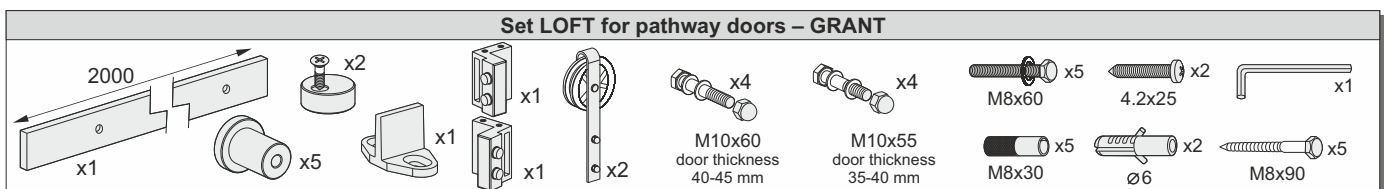

4. Installation of Wheel

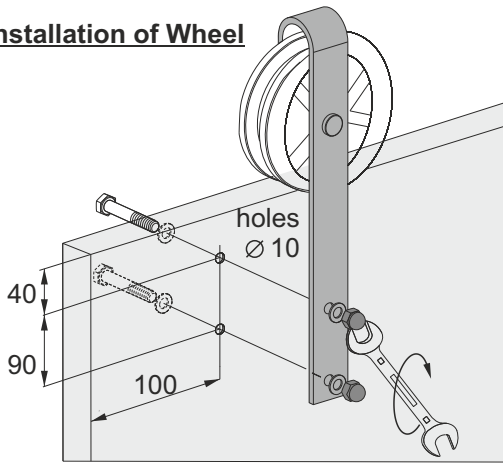

5. Bumper installation

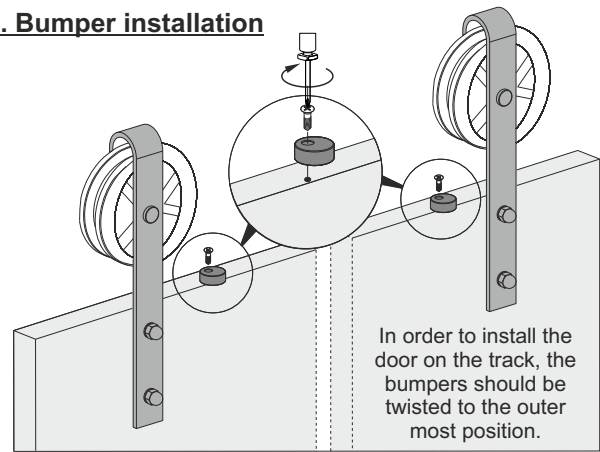

6. Door installation

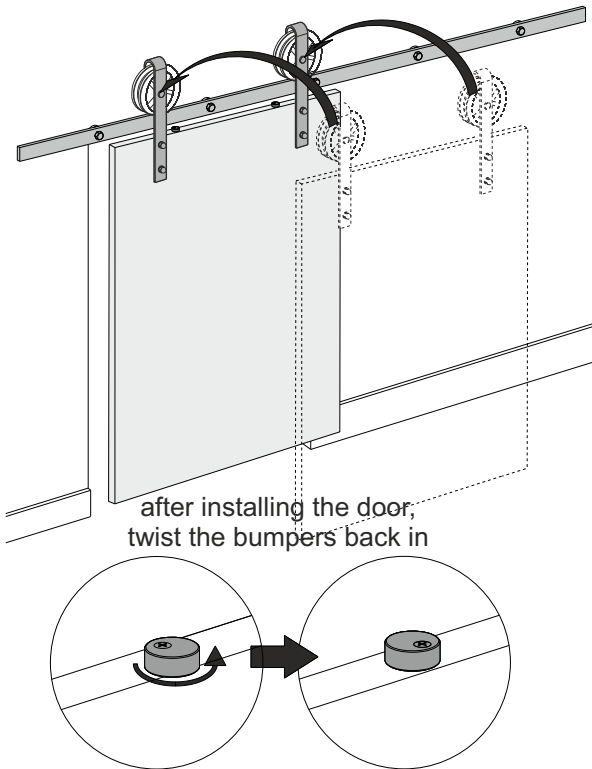

7. Guide installation

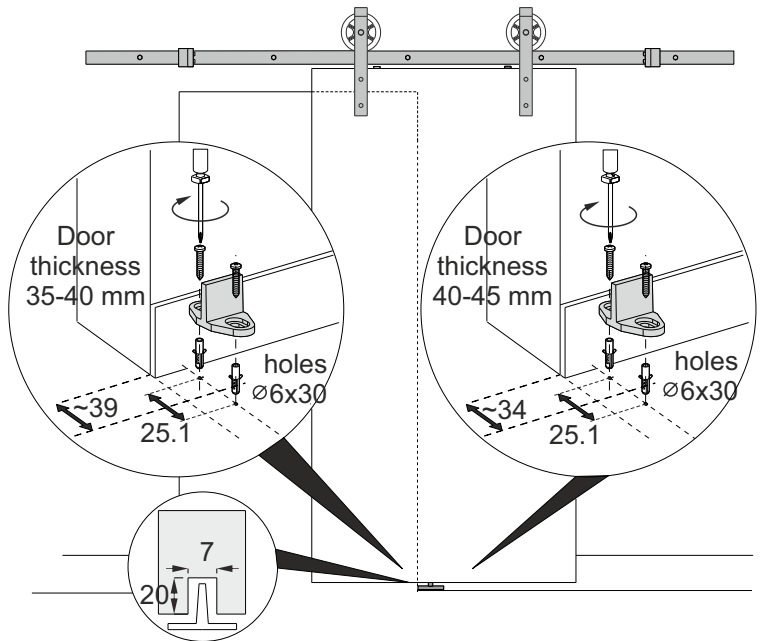

8. Position the stoppers on the track

