

COMPONENTS

Top track Mars

L: 1.20 m, 1.80 m, 3.00 m, 3.60 m

40

Set for sliding doors Mars (1 wing)

x2 $\varnothing 3.5 \times 16$ x2
x8
carriage Mars
Stopper
Universal guide

OPTIONS

Soft-close Mars MINI

25 kg - index 05241
40 kg - index 05242

Soft-close installation

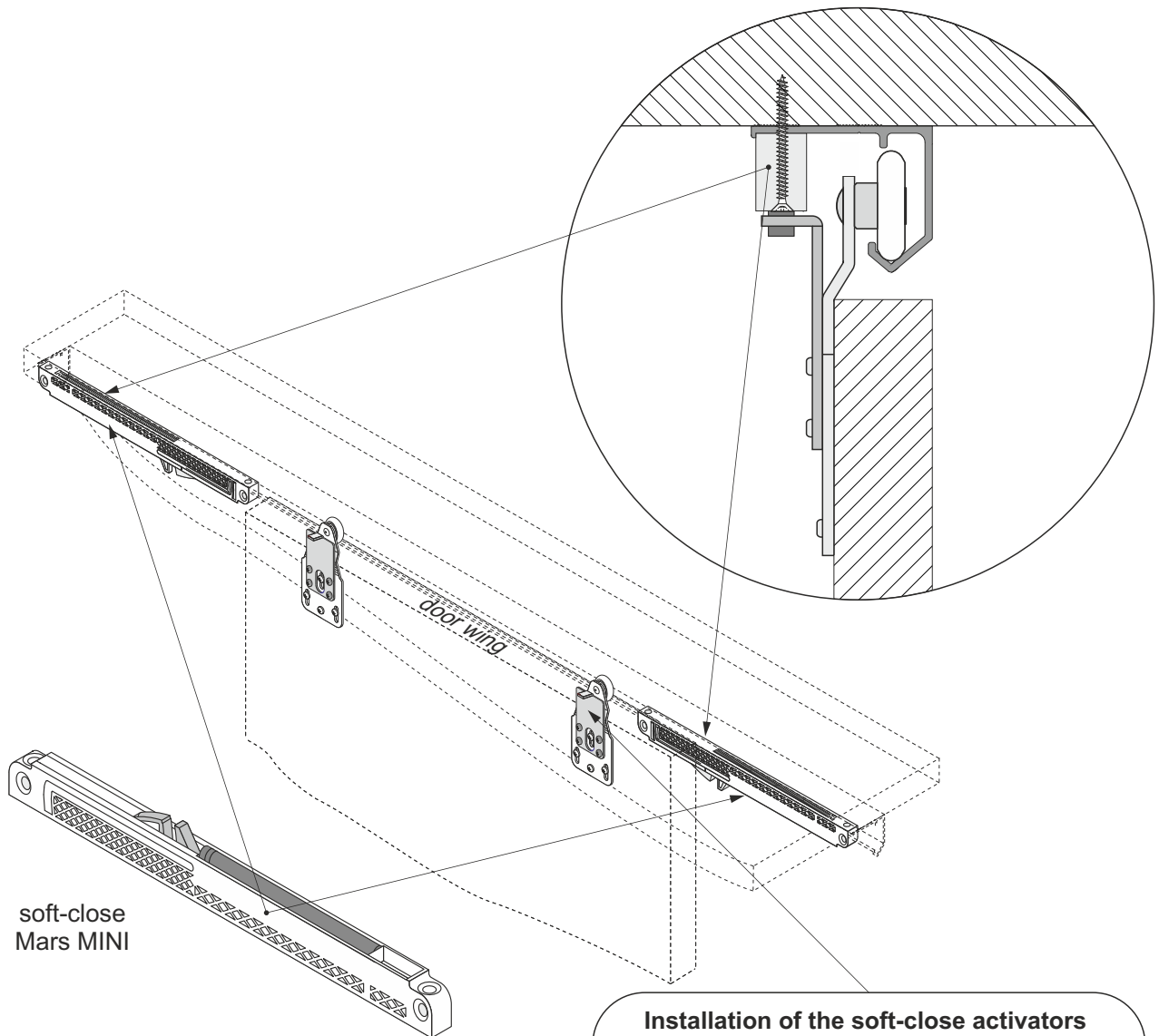
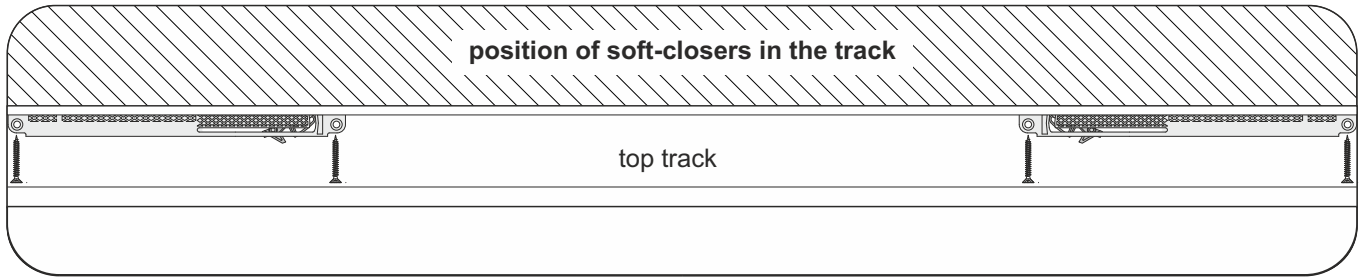

Installation of the soft-close activators (after adjusting the door wing)

