

**COMPONENTS**

<p><b>Top track Merkury</b></p>	<p><b>Set for sliding doors Merkury (2 wings)</b></p> <p>carriages D1 x2 carriages D2 x2 Stopper x2 Universal guide screws <math>\varnothing 3.5 \times 16</math> x16</p>	<p><b>Set for sliding doors Merkury (1 wing)</b></p> <p>carriage D3 x2 Stopper x1 Universal guide screws <math>\varnothing 3.5 \times 16</math> x8</p>
---------------------------------	---	--

**OPTIONS**

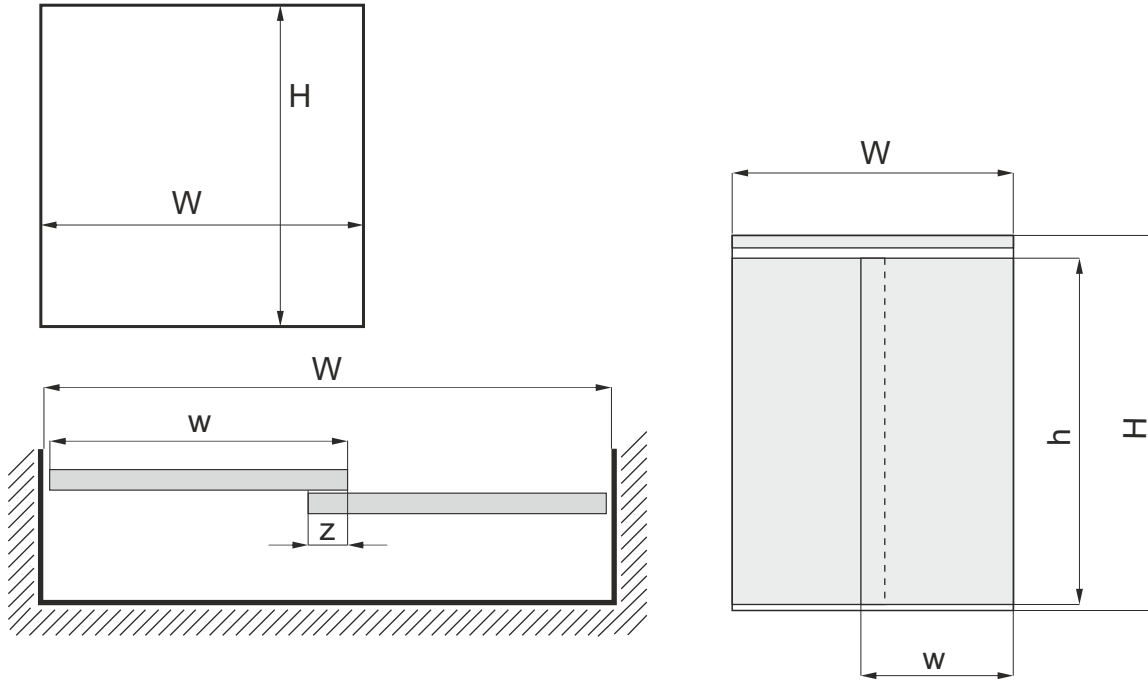

<p><b>Soft-close MINI</b></p> <p>25 kg - index: 20359-SV 40 kg - index: 20260-SV</p>
<p><b>Soft-close Merkury CENTRAL</b></p> <p>25 kg - index 5243 40 kg - index 5244</p>

Dimensions of opening



door height	- h	$h = H - 50 \text{ mm}$
door width	- w	$w = (W + Z) : N$

number of doors	- N	2	3	4
total overlap	- Z	40 mm	80 mm	120 mm

visual design - 4 wings	
 układ drzwi	$w = (W + 120) : 4$
 układ drzwi	$w = (W : 2 + 40) : 2$

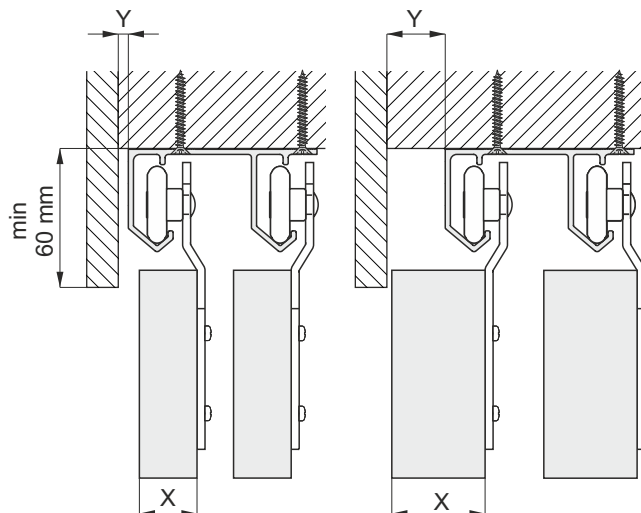

X [mm]	16	18	19	22	25	28	32	40
Y [mm]	0	1	1	4	15	18	22	30

Two door configuration

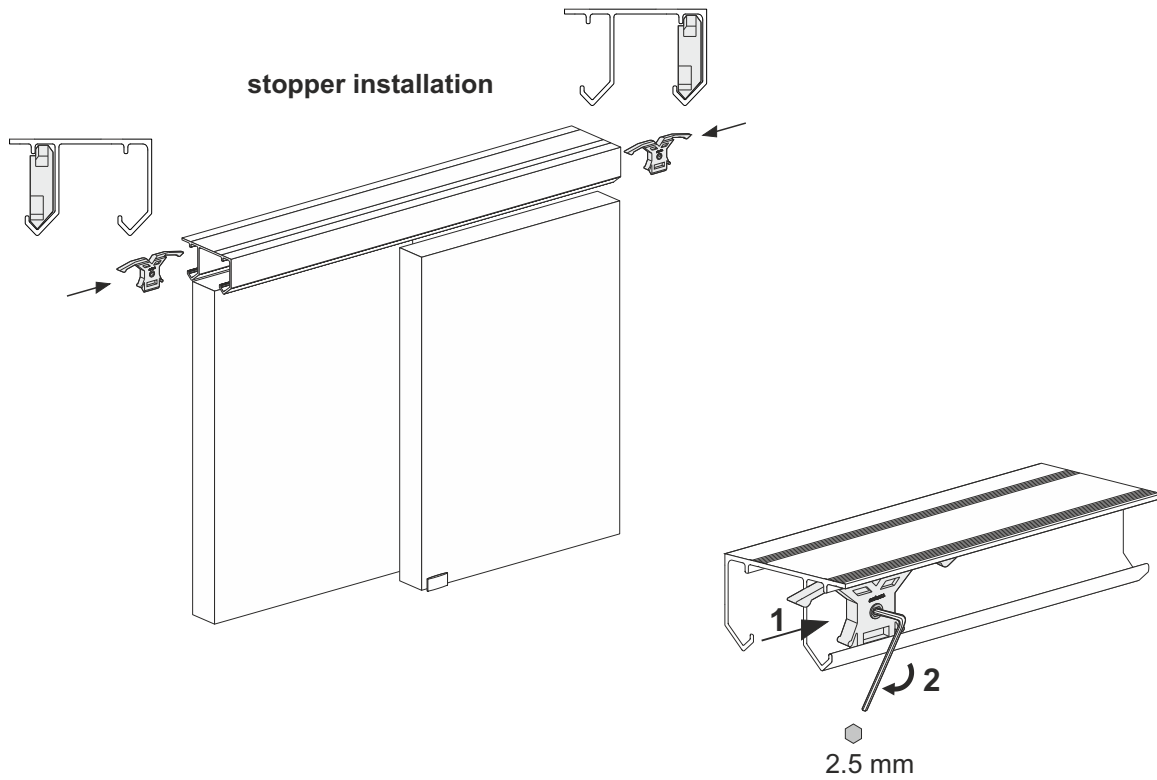

Three door configuration

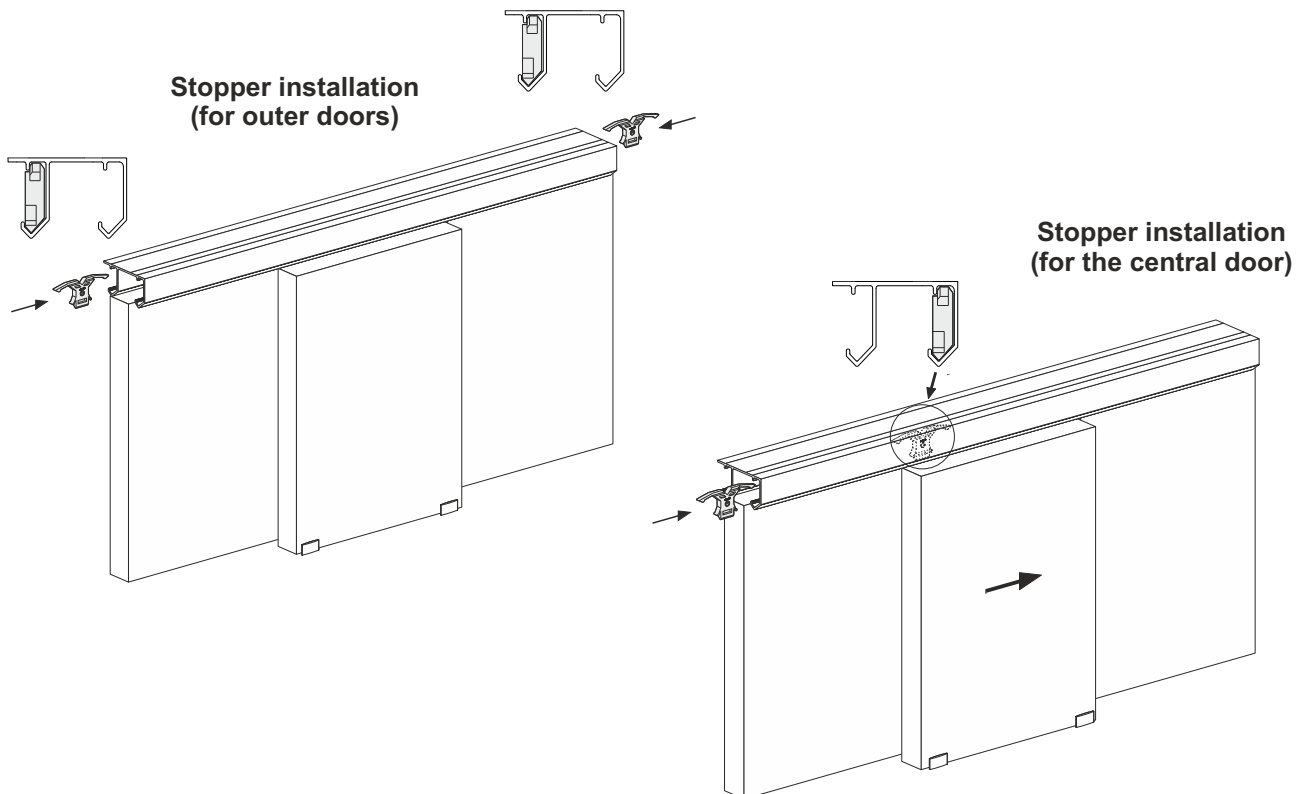

**Attention**

If you use a **stopper** for the central door, it will only be possible to open it in one direction, left **or** right (depending on which side you attach the stopper).  
When using our **central soft-close**, the central door can be opened **in both directions**.

**Soft-close installation**

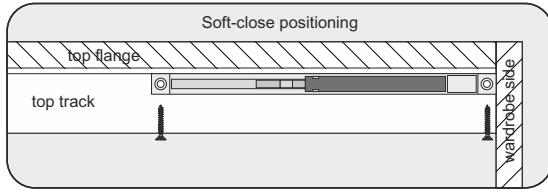

**Soft-close MINI**

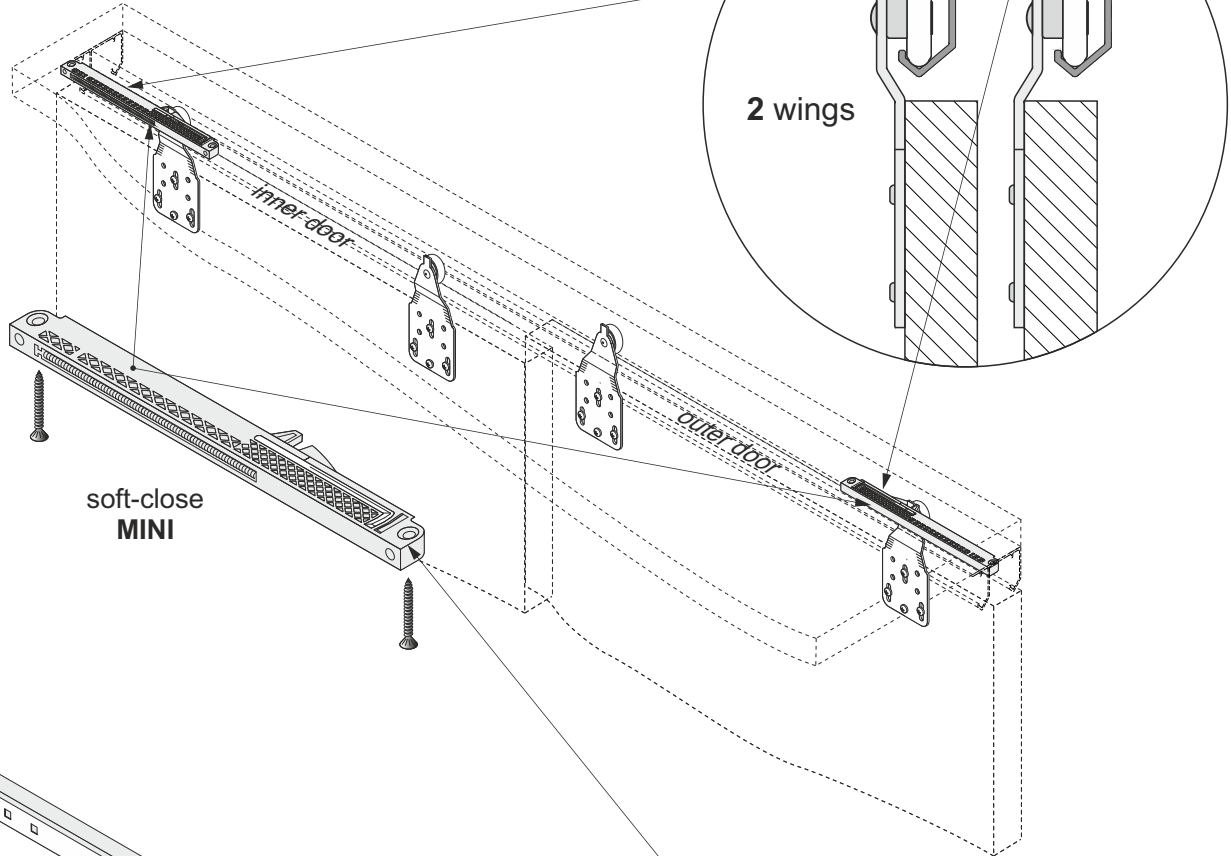

**Soft-close CENTRAL**

