

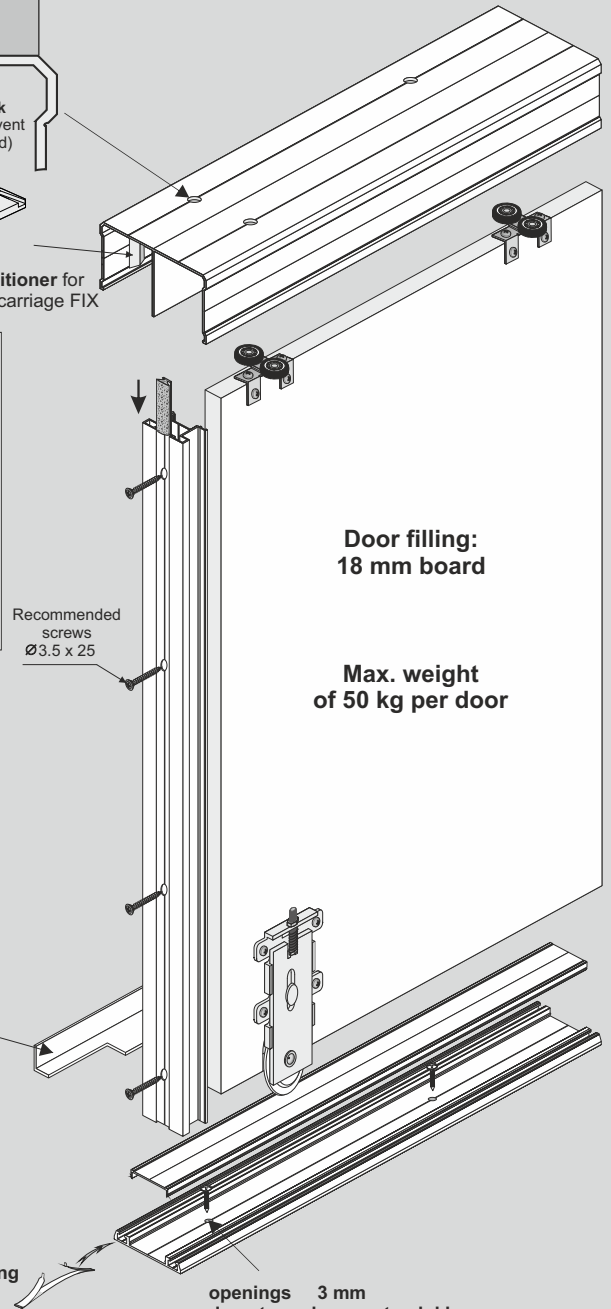

Door fitting order

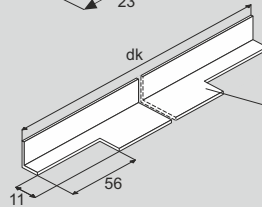
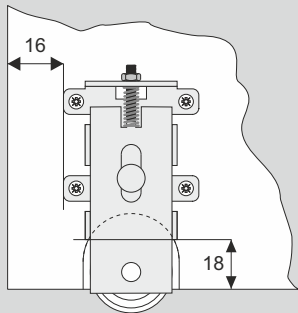
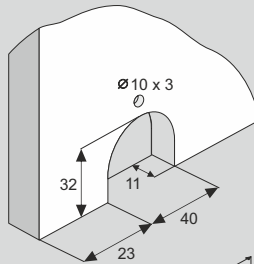
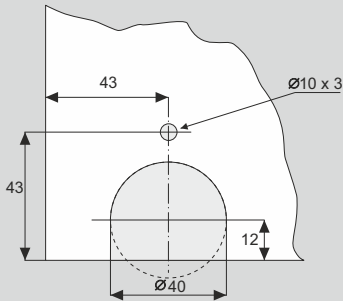
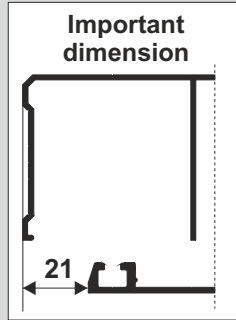
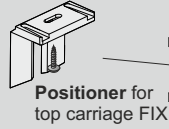
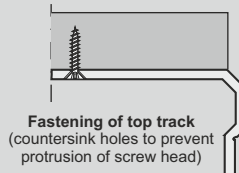
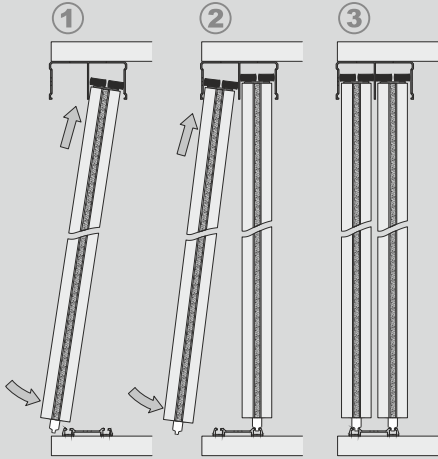

ATTENTION:
For fast and accurate routing of the bottom carriage pockets we recommend using stencil for bottom carriage WD18 HI-TEC index 20191

COMPONENTS

Handle

L: 2.70 m L: 2.70 m

3.00 m

PORTO PROSPER II

Top track Maxim

L: 1.80 m
2.50 m
3.50 m
4.30 m
6.00 m

83 mm

**Bottom track Maxim II (A)
Covering strip Maxim II (B)**

L: 1.80 m, 2.50 m, 3.50 m,
4.30 m, 6.00 m

51 mm

Stopper HI-TEC

Guiding carriage Maxim Board

Bottom track WD18V HI-TEC

Angle section Mini

L: 1.70 m
2.35 m
3.00 m

11 mm x 17 mm

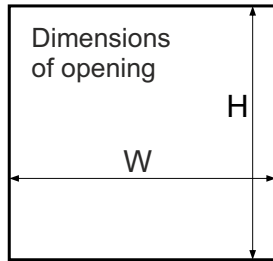

		Handle length = door height			
		LINE PORTO		LINE PROSPER	
		Handle Porto	Carriage Maxim 18 Board	Handle Prosper II	Carriage Maxim 18 Board
		Textile door stop inserted 14 mm x 4 mm	L/R	Textile door stop inserted 14 mm x 4 mm	L/R
door height	- h	$h = H - 40 \text{ mm}$		$h = H - 40 \text{ mm}$	
door wing height with soft-close fitted		Mini SV25/40/60 SV-25/50	$h = H - 40 \text{ mm}$	Mini SV25/40/60 SV-25/50	$h = H - 40 \text{ mm}$
		Top SV60/80 Central SV25/40	$h = H - 44 \text{ mm}$	Top SV60/80 Central SV25/40	$h = H - 44 \text{ mm}$
board height	- hb	$hb = h - 2 \text{ mm}$		$hb = h - 2 \text{ mm}$	
door width	- w	$w = (W - 3 \text{ mm} + Z) : N$		$w = (W - 3 \text{ mm} + Z) : N$	
board width	- wb	$wb = w - 41 \text{ mm}$		$wb = w - 31 \text{ mm}$	
angle section mini length	- la	this size is determined after door construction		this size is determined after door construction	

number of doors	- N	2	3	4	5	2	3	4	5
total overlap	- Z	30 mm	60 mm	90 mm	120 mm	25 mm	50 mm	75 mm	100 mm

visual design – 4 wings		
	$w = (W - 3 + 90) : 4$	$w = (W - 3 + 75) : 4$
	$w = (W : 2 + 27) : 2$	$w = (W : 2 + 22) : 2$

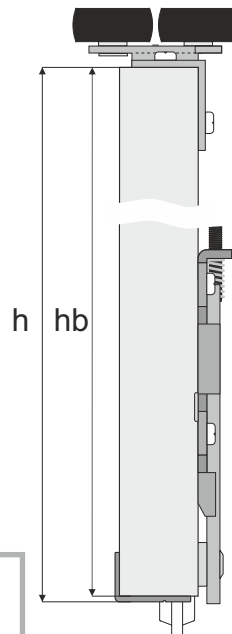
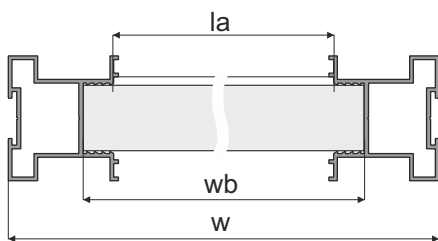

- When fitting handle profiles, do not use assembly adhesive
- The tapped handle screw to the plate with screws according to instructions

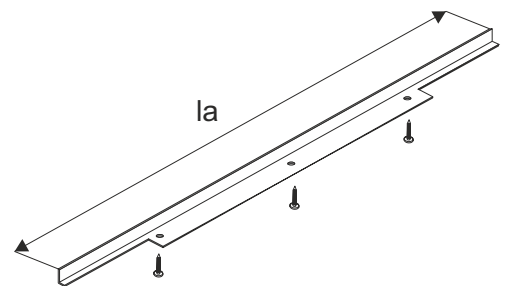

WARNING

SEVROLL does not bear any responsibility for deformation resulting from the application of improper quality of boards (improper storage, improper humidity)

ATTENTION!

Handle profile should be 2 mm longer than board height.

ATTENTION!

Remove protective film from aluminium elements (handles, tracks, connectors, etc.) prior to cutting them to the desired size. Film removal will reveal quality issues (eg. scratches)