

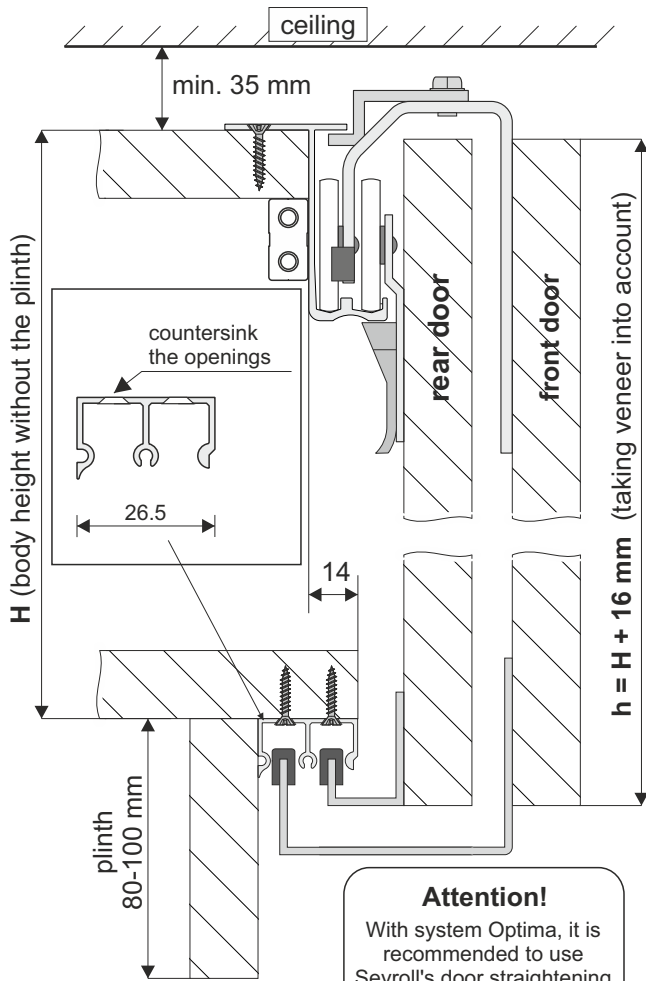

SYSTEM

OPTIMA 18 – for 2 wings



ATTENTION

Door height should be greater than body height (without the plinth) by exactly 16 mm.
 Top flange should be moved back by 14 mm in relation to the bottom flange and should be fastened firmly.
 Thickness of board: max. 20 mm.

Rear door assembly

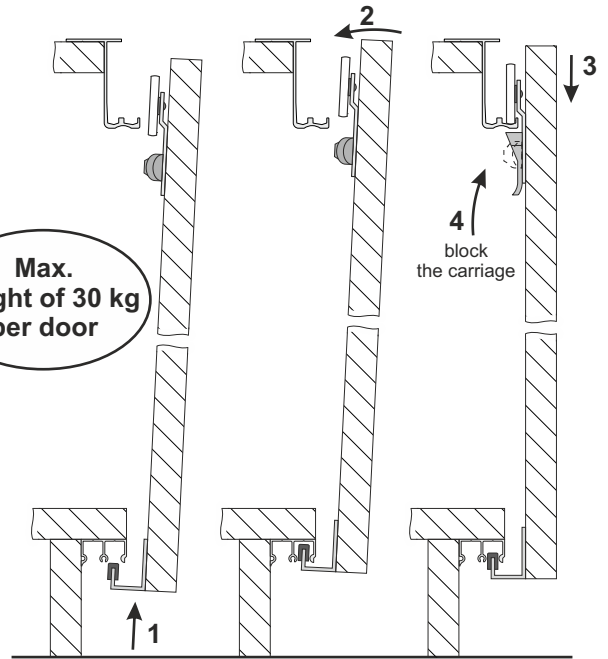

Attention!

With system Optima, it is recommended to use Sevroll's door straightening kits to eliminate the chance of door bowing

Front door assembly

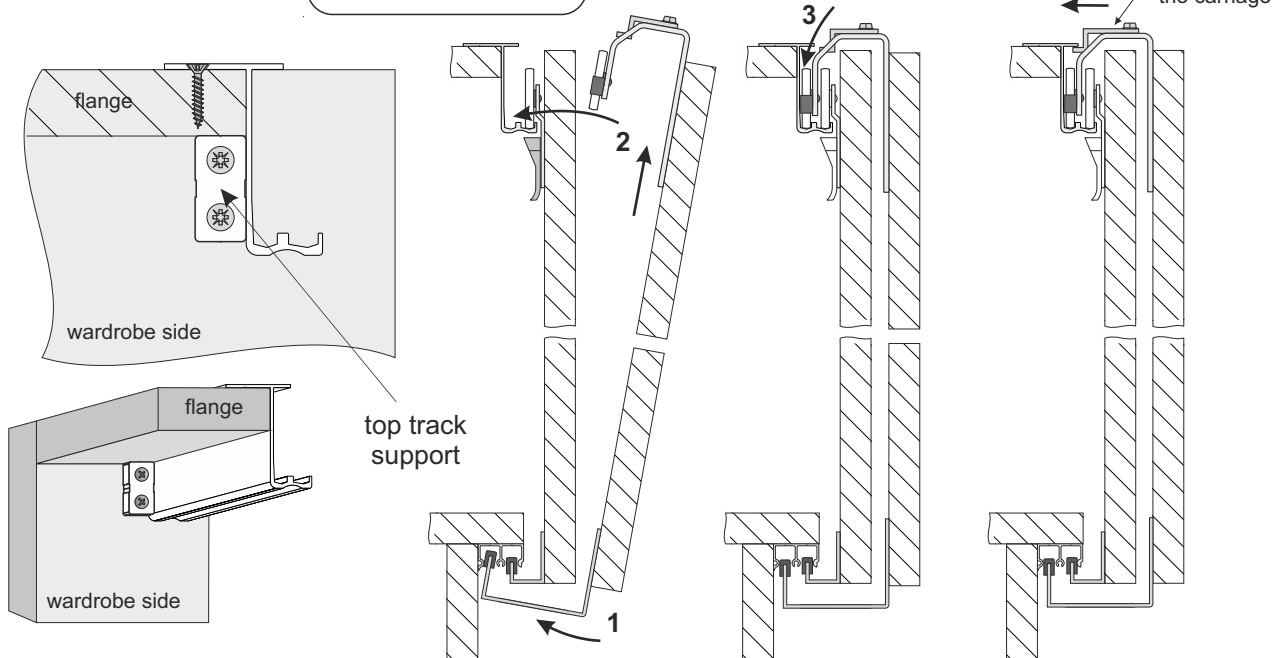

COMPONENTS

Top track Optima

L: 2.00 m, 2.40 m, 6.00 m

43

Bottom track Optima

L: 2.00 m, 2.40 m, 6.00 m

26

Set for sliding doors Optima II – 2 door wings

x2 x1 x1 x2 x2 x2 x2

OPTION

Handle Optima

L: 2.40 m

textile door brush inserted 14 x 4 mm (set B)

textile door brush inserted 4 x 4.8 mm (set A)

#16, #18



SYSTEM

OPTIMA 18 – for 2 wings



board width calculation

door without vertical profiles
(taking edging into account)

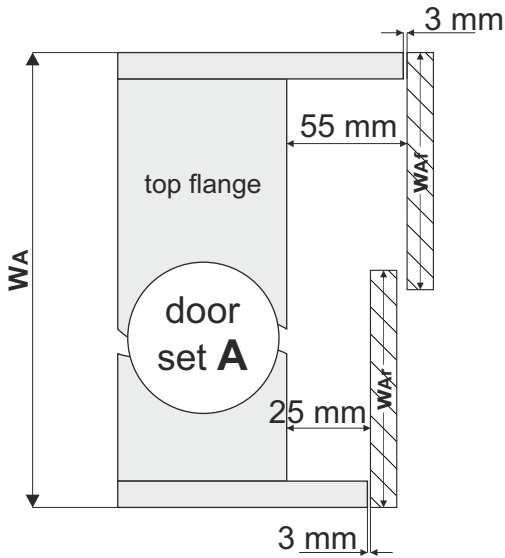

$$WA_f = WA_r = (WA + 20 \text{ mm}) : 2$$

door with vertical profiles (handles)
rear door - 1 handle
front door - 2 handles

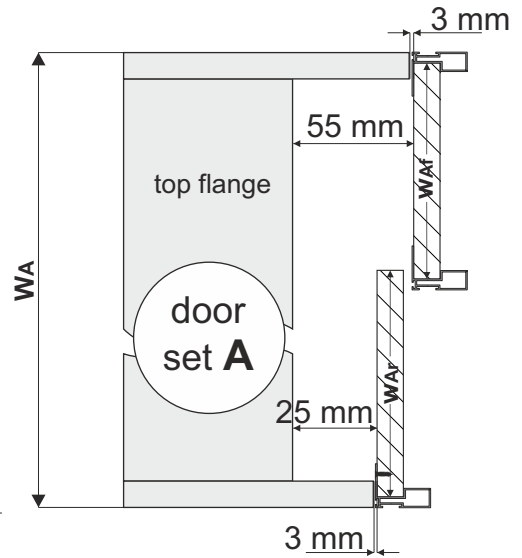

$$WA_f = [(WA + 20 \text{ mm}) : 2] - 14$$

$$WA_r = [(WA + 20 \text{ mm}) : 2] - 7$$

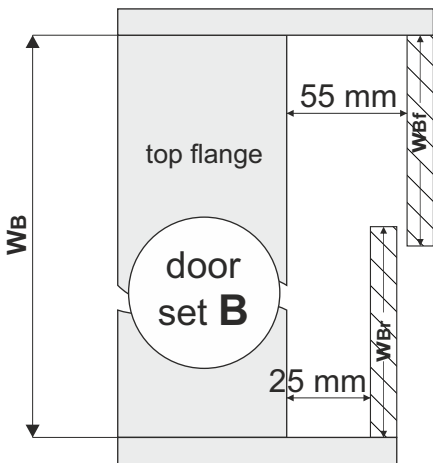
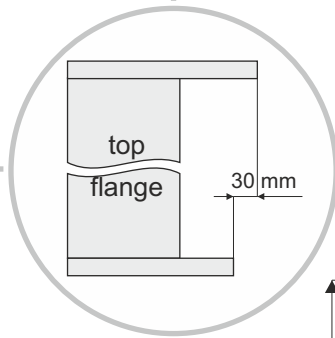

$$WB_f = WB_r = (WB + 20 \text{ mm}) : 2$$

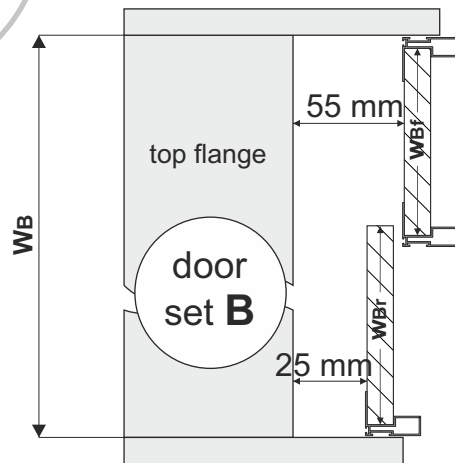

$$WB_f = [(WB + 20 \text{ mm}) : 2] - 14$$

$$WB_r = [(WB + 20 \text{ mm}) : 2] - 7$$

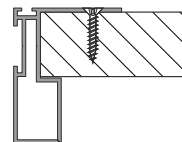

handle to be fastened with a minimum of 4 screws



SYSTEM

OPTIMA 18 – for 2 wings



Fastening of carriages and guides to the rear door

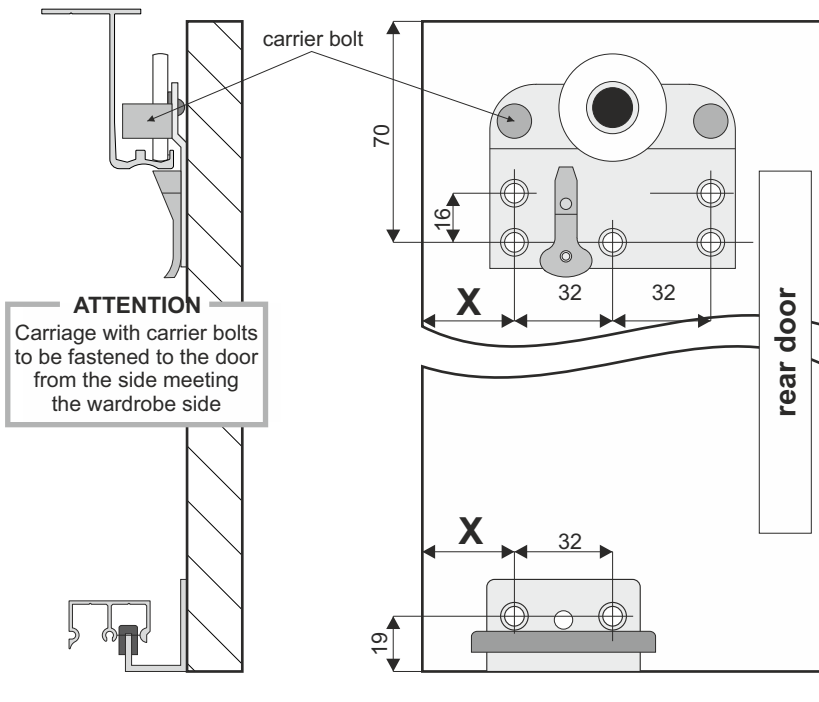

Fastening of stopper to the top track

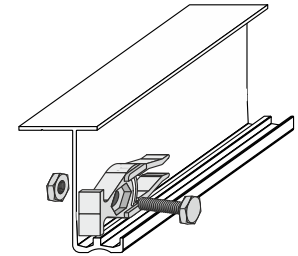

drill an opening in a track $\varnothing 6$

rear door (set A and B)
door without and
with vertical profiles (handles)

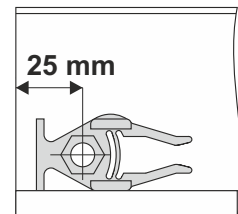

front door (set A and B)
door without and
with vertical profiles (handles)

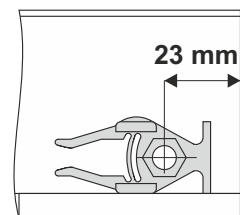

Fastening of carriages and guides to the front door

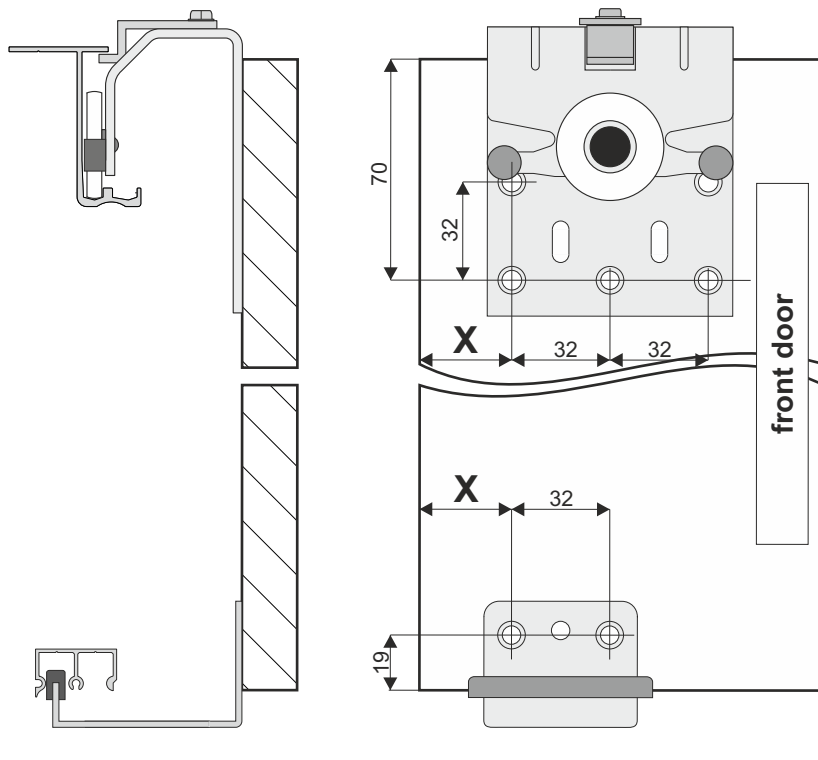

distance	door without vertical profiles		door with vertical profiles (handles)	
	door set A	door set B	door set A	door set B
x	58 mm	40 mm	51 mm	31 mm



Optionally, instead of stoppers, soft-closes **Optima** can be used (purchased separately)



SYSTEM

OPTIMA 18 – for 2 wings



**Option with mirror (only available for front door wing)
door set A and B**

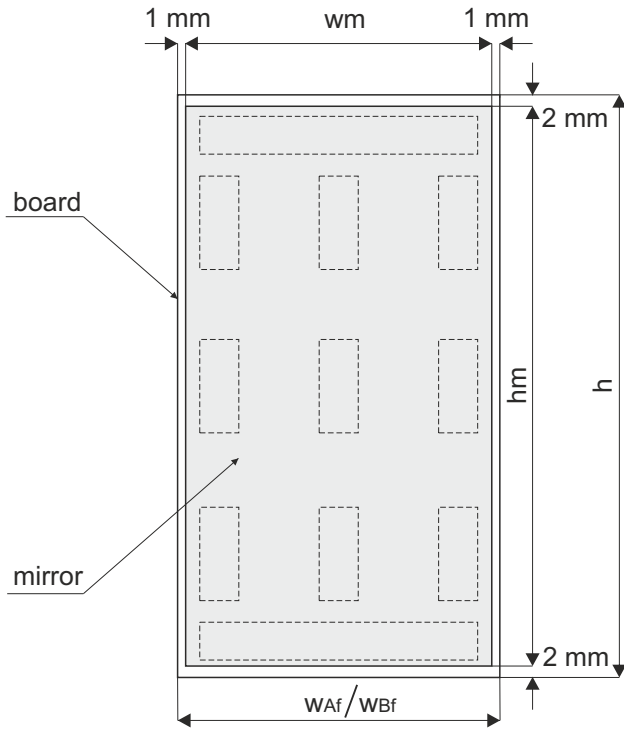

Broken line indicated recommended positioning of double-sided tape

ATTENTION :

Board to mirror contact area should be free from dirt and grease before applying double-sided tape

mirror dimensions

wm = $W_{Af}/W_{Bf} - 2 \text{ mm}$

hm = $h - 4 \text{ mm}$

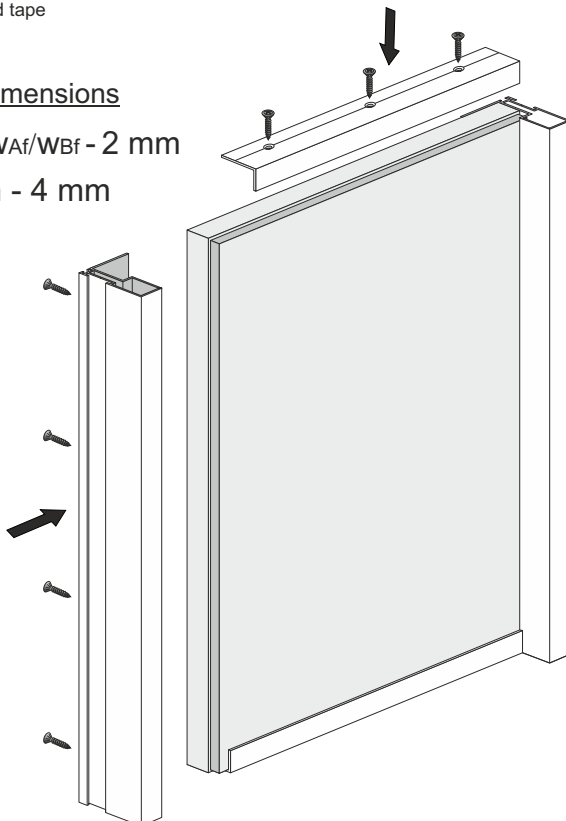

ATTENTION!

Use angle section MINI

The usage of angle section requires the handle to be 3 mm longer than board size (protruding by: 1.5 mm - top, 1.5 mm - bottom)

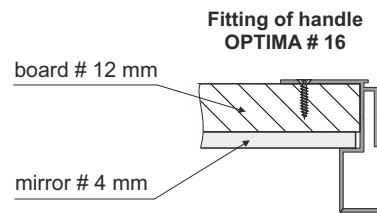

Fitting of angle section MINI

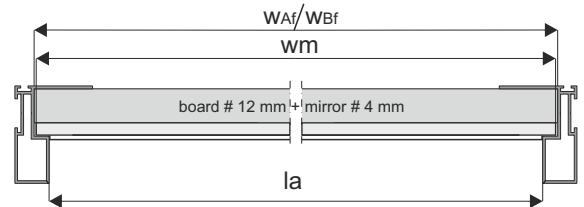
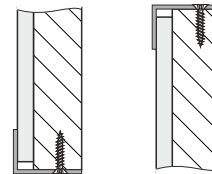

la - angle section MINI length

la = $W_{Af} - 12 \text{ mm}$



for aesthetic reasons, the angle section length should be decided after handle fitting

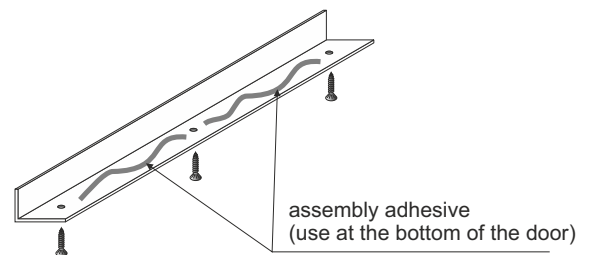

ATTENTION!

Angle section must be fastened to board with a minimum of 3 screws 3x25