

COMPONENTS

Frame Secret Line	
L: 2.70 m	L: 2.70 m
SECRET LINE	SLIM LINE

Inset hinge (cup ø 35 mm, hole spacing 45 mm) with clip on and soft close
x4

Magnetic catch
x2

Textile door stop 4.8 mm x 4 mm	
self-adhesive (SECRET LINE)	inserted (SLIM LINE)

Screws
screw 2.5x16 (frame) x 14 pcs



LINE

SYSTEM

DR SECRET LINE, DR SLIM LINE / DR FRAME LINE

Dimensions of opening

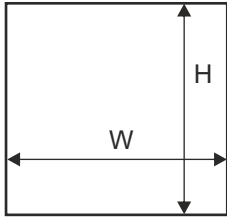

		LINE SECRET LINE	LINE SLIM LINE
door height	- h	$h = H - 6 \text{ mm}$	$h = H - 6 \text{ mm}$
board height	- hb	$hb = h - 3 \text{ mm}$	$hb = h - 6 \text{ mm}$
single door system	door width	- w	$w = W - 6 \text{ mm}$
	door width	- w	$w = W - 6 \text{ mm}$
two door system	door width	- w	$w = (W - 9 \text{ mm}) : 2$
	door width	- w	$w = (W - 8 \text{ mm}) : 2$
board width	- wb	$wb = w - 3 \text{ mm}$	$wb = w - 6 \text{ mm}$

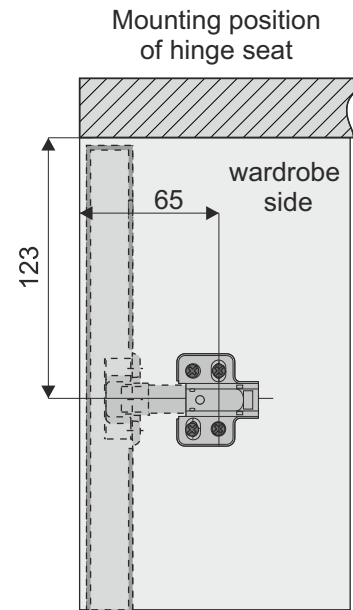

Max. weight of
4 kg per 1 hinge

The weight 1 m² of 18 mm board = 13 kg

Method for positioning hinge recesses

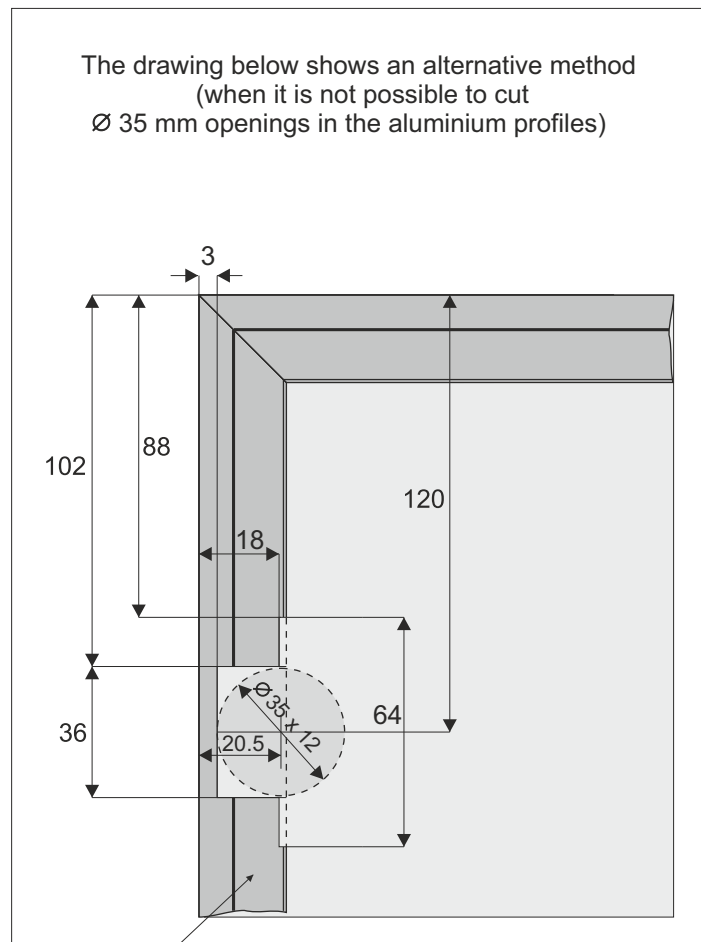
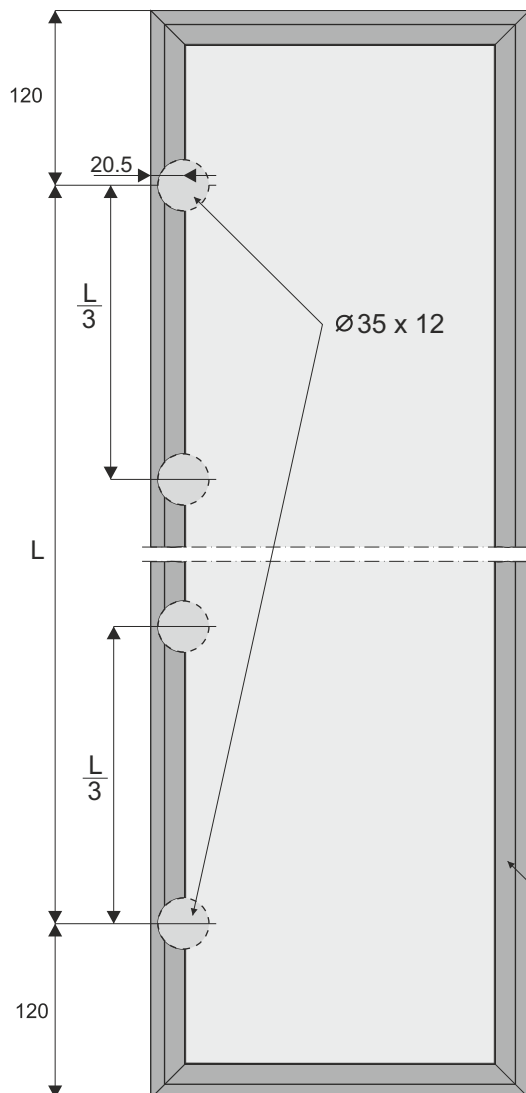

Frame SECRET LINE or SLIM LINE

ATTENTION!

Remove protective film from aluminium elements (handles, tracks, connectors, etc.) prior to cutting them to the desired size. Film removal will reveal quality issues (eg. scratches)