

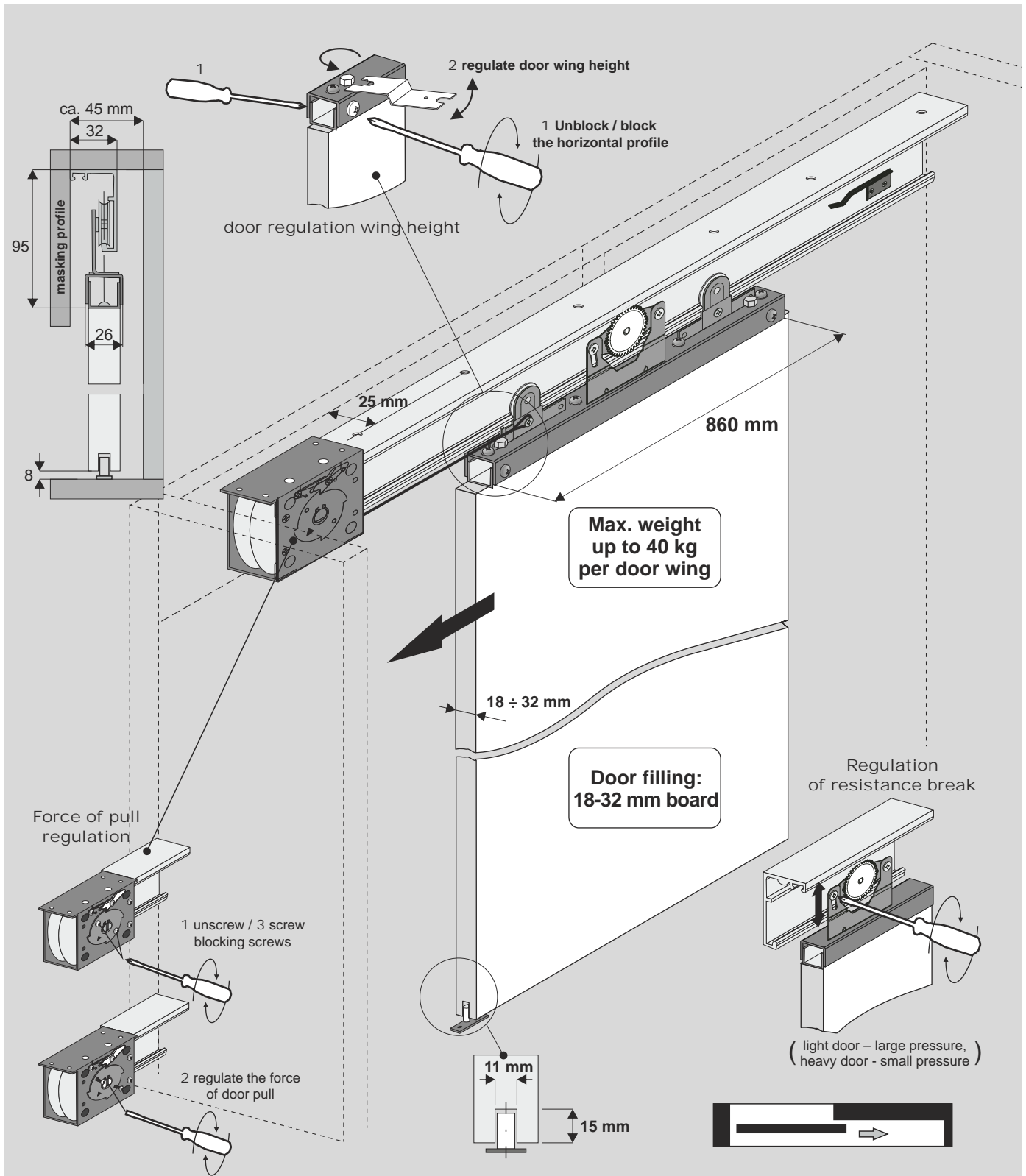

SEVROMATIC

AUTOWALL



COMPONENTS

AUTOWALL set (1 wing) – left or right

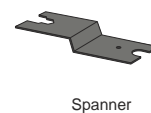
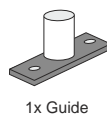
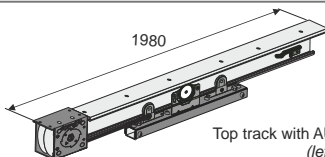

- Ø5 x 30 - 10 pcs (for track and hor. profiles)
- Ø4 x 16 - 2 pcs (for the box with pulling mechanism)
- Ø3,5 x 20 - 2 pcs (for guide)

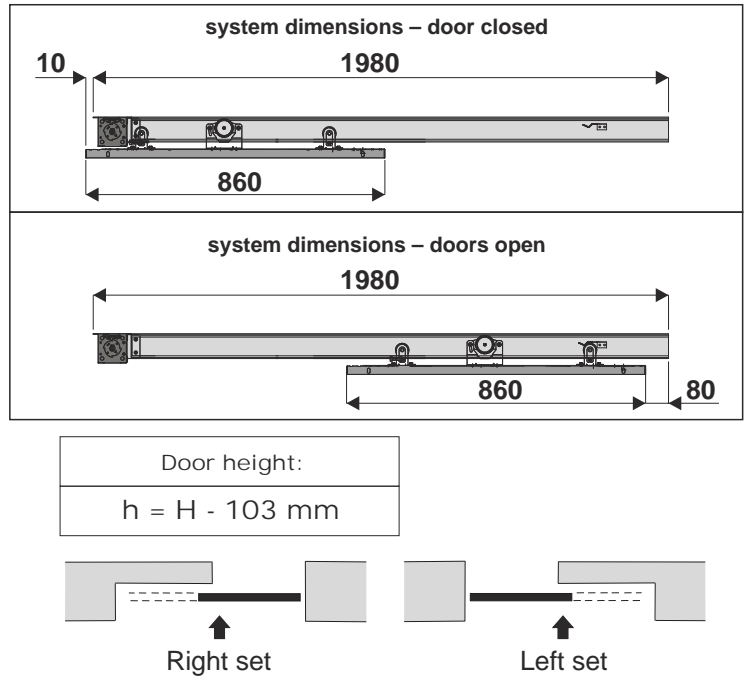
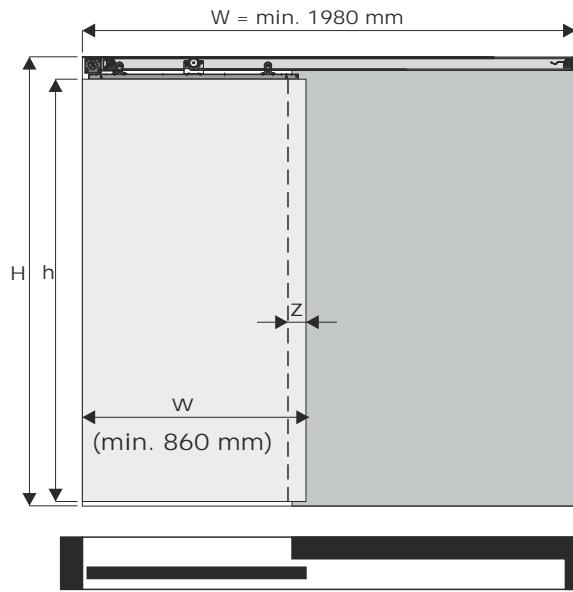

Door assembly

