



SYSTEM

DR FRAME

SEVROLL



inset door

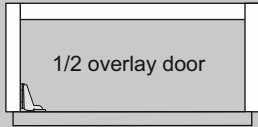

1/2 overlay door

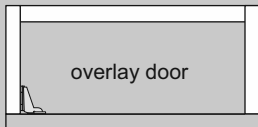

overlay door

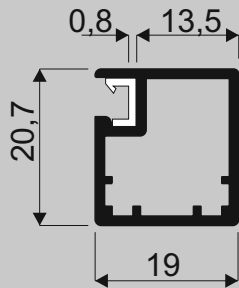

Frame S01 II

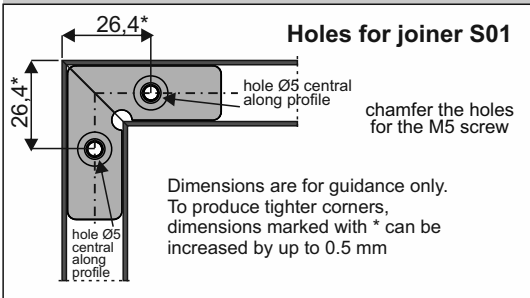
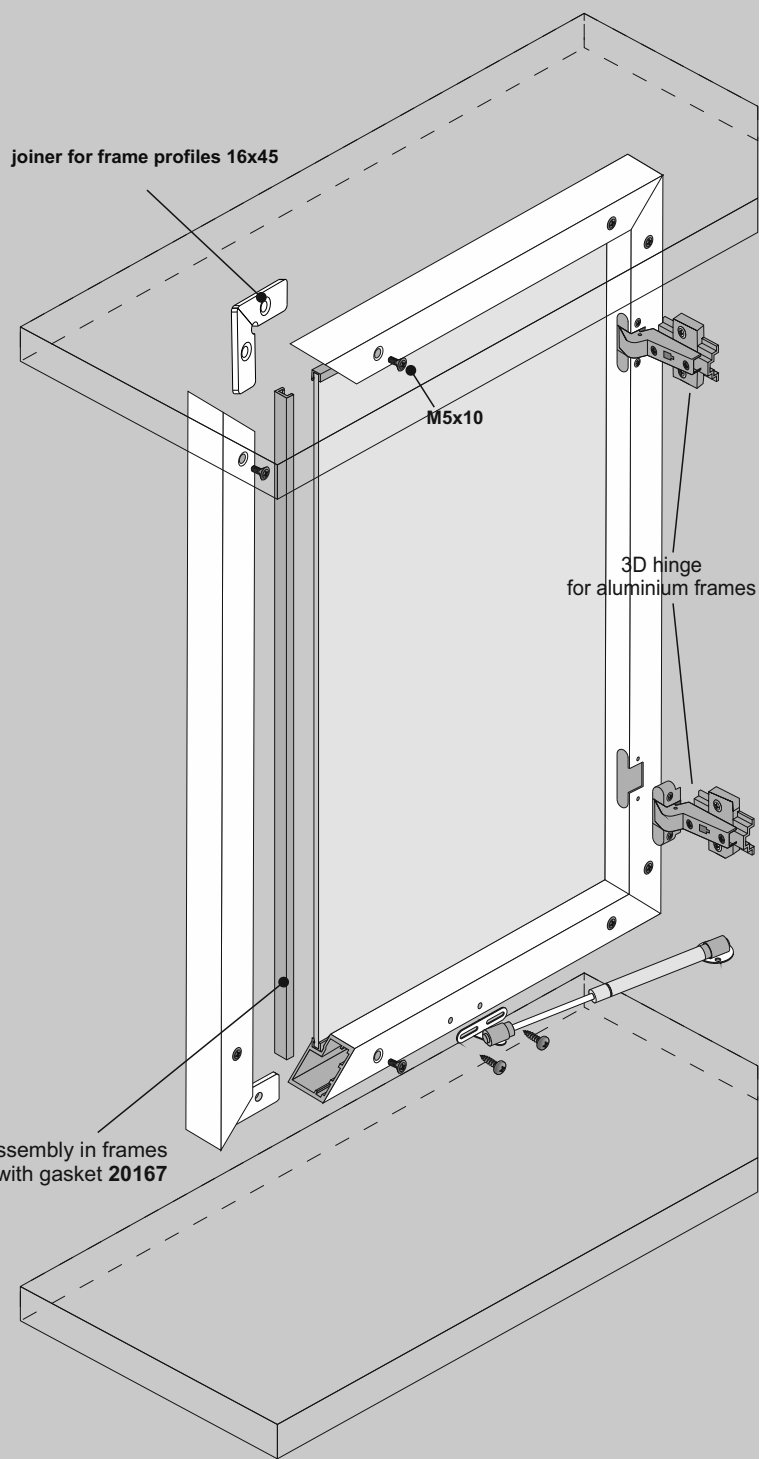

COMPONENTS

Frame profile
L.: 4,00m

S01 II

3D hinge for aluminium frames

- inset
- half overlay
- full overlay

Joiner for frame profiles S01 (16x45)

S01 (20008)

Gasket for frame profiles type II S01, S02, S04, S05, S06

(20167)

Lid stay

ATTENTION!

Remove protective film from aluminium elements (handles, tracks, connectors, etc.) prior to cutting them to the desired size. Film removal will reveal quality issues (eg. scratches)



SYSTEM

DR FRAME

SEVROLL

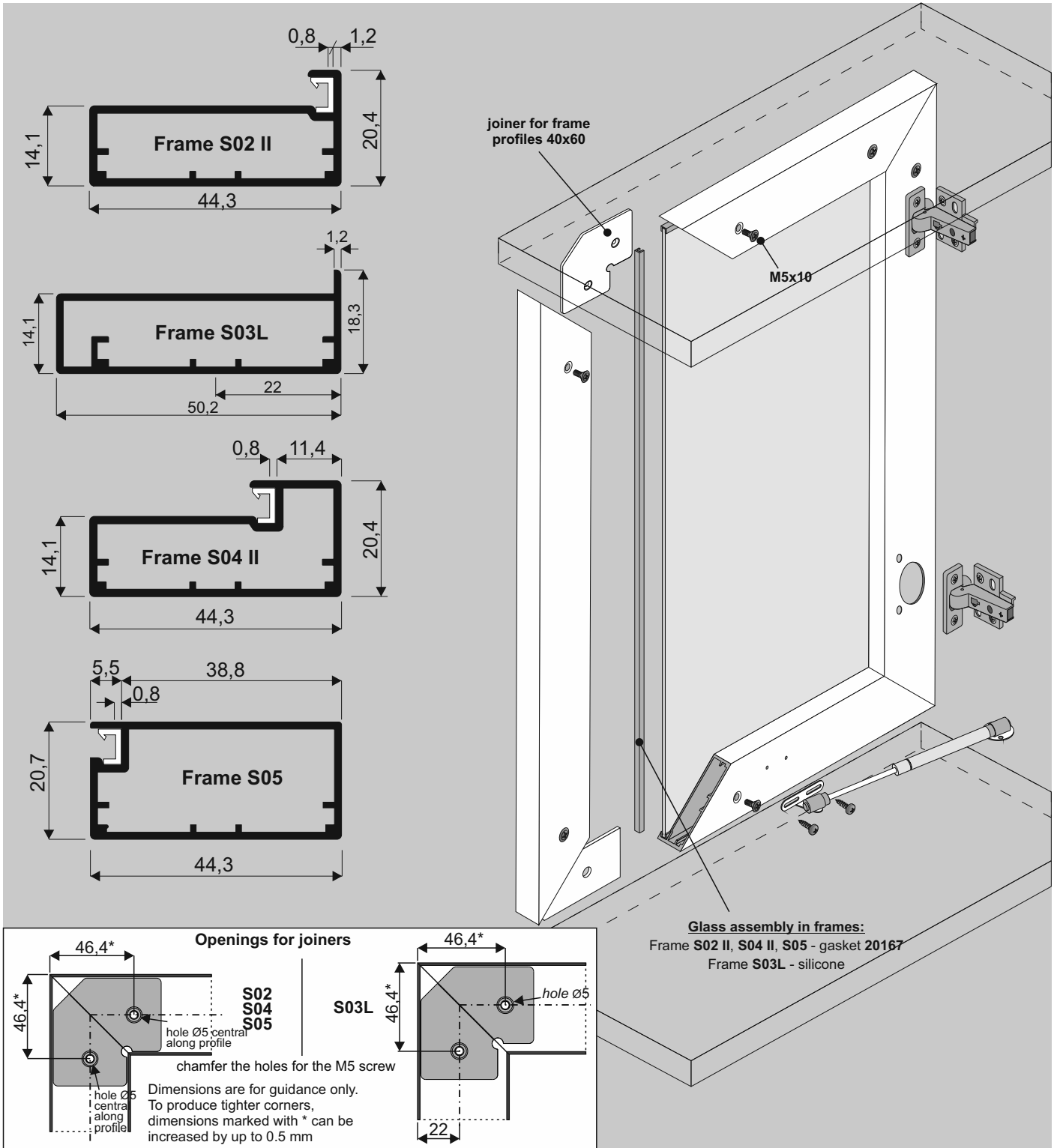

COMPONENTS

Frame profile
L.: 4,00m

S02 II S03L S04 II S05

Hinge Ø35 clip on with soft close

x2

- inset
- half overlay
- full overlay

Joiner for frame profiles S02, S03L, S04, S05 (40x60)

S02, S03L, S04, S05 (20010)

Gasket for frame profiles type II S01, S02, S04, S05, S06

(20167)

Lid stay

ATTENTION!

Remove protective film from aluminium elements (handles, tracks, connectors, etc.) prior to cutting them to the desired size. Film removal will reveal quality issues (eg. scratches)



SYSTEM

DR FRAME

SEVROLL

Assembling the H04 connector for S01 and S05 frames

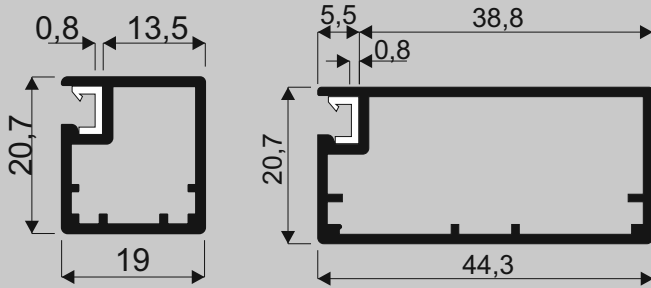

Frame S01 II

Frame S05

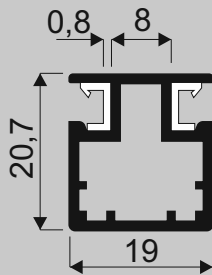

midrail H04 for frames S01 and S05

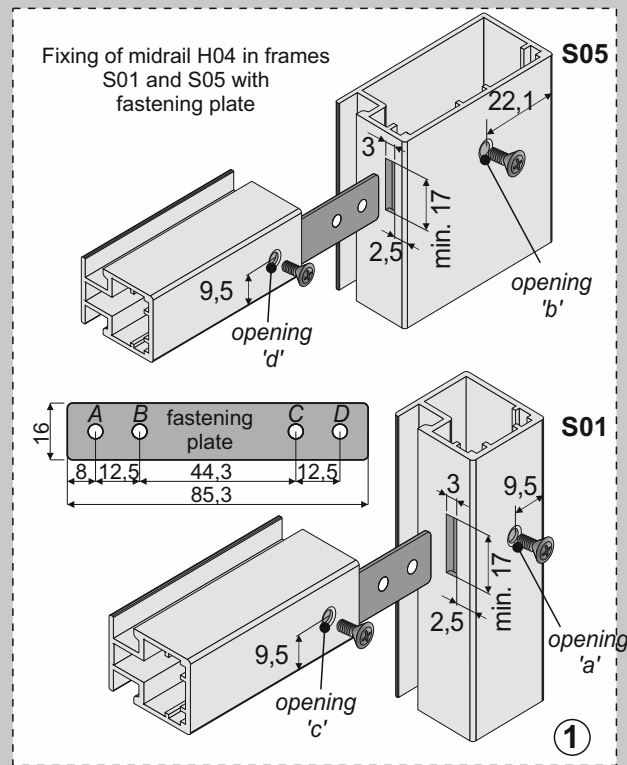
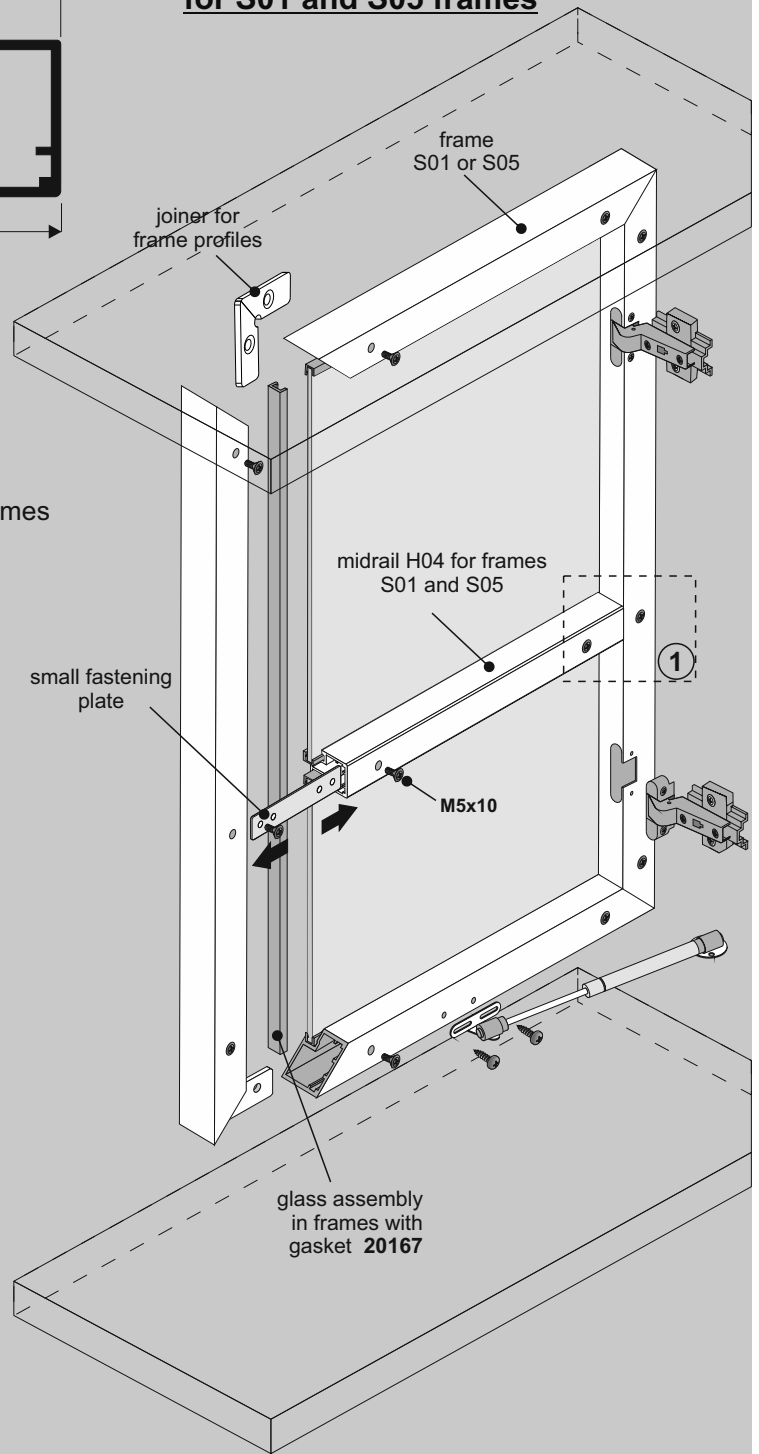

ADDITIONAL COMPONENTS

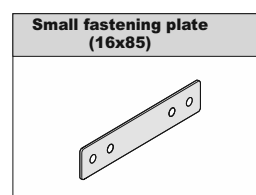
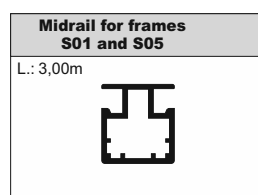

ATTENTION!

Remove protective film from aluminium elements (handles, tracks, connectors, etc.) prior to cutting them to the desired size. Film removal will reveal quality issues (eg. scratches)



Connecting strengthening profile with frames S01, S02, S04, S05

Strengthening profile S01, S02, S03L, S04, S05 (14x50 mm)

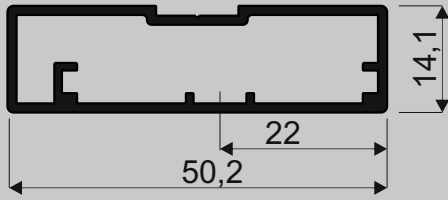

Fixing of strengthening profile for frames S01 S02 S03L S04 and S05 with large fastening plate

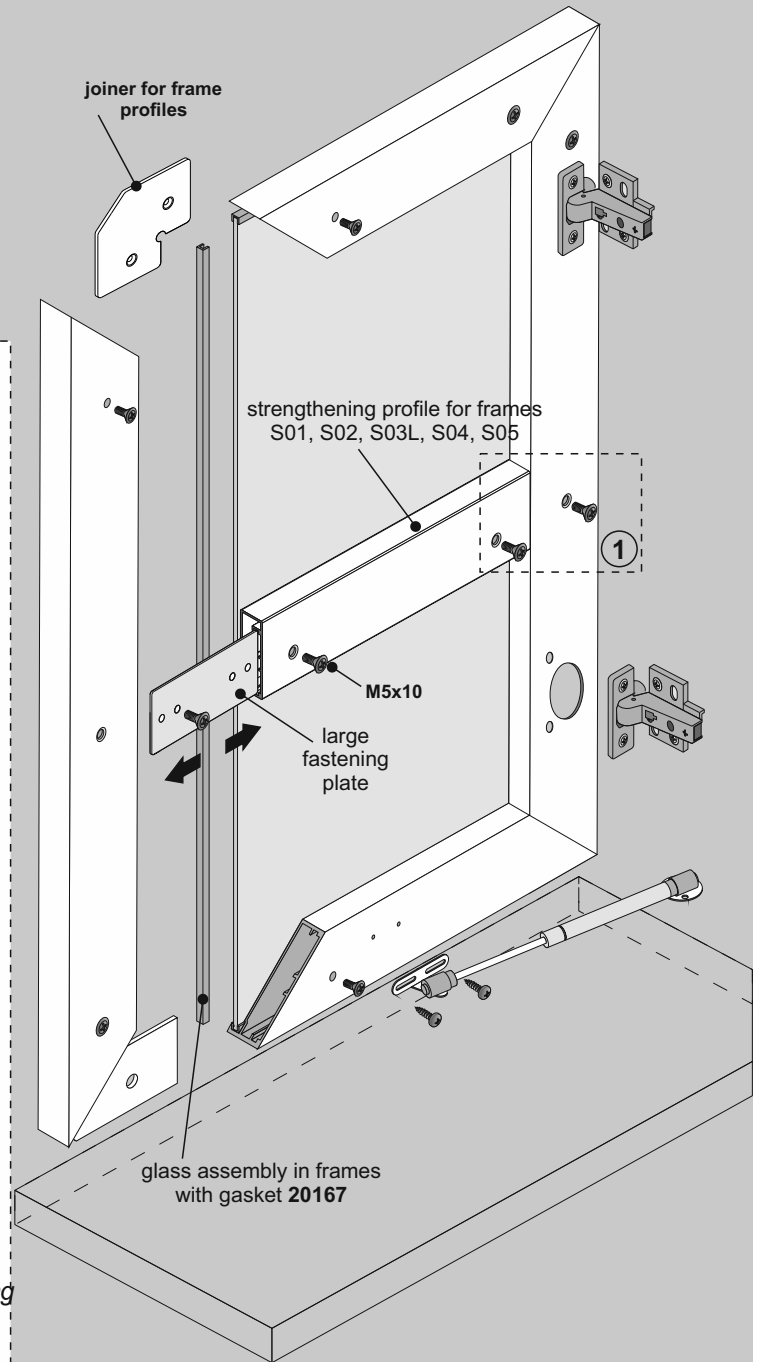
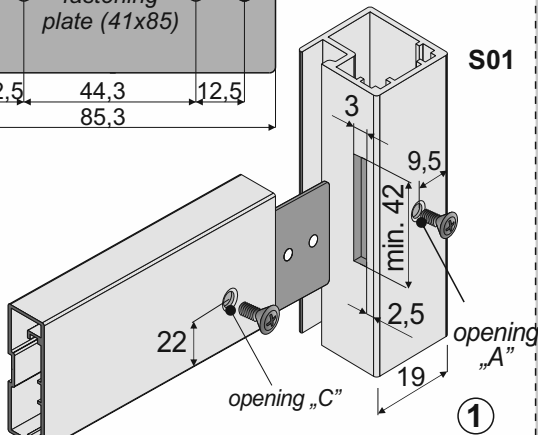
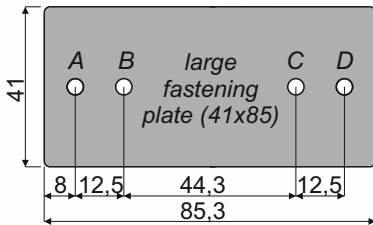
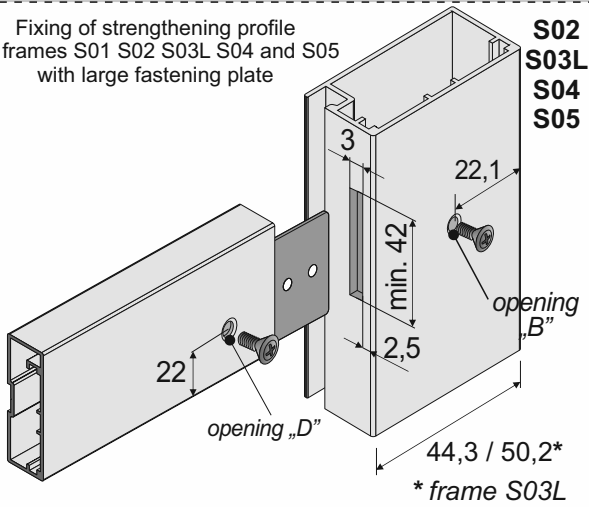

ADDITIONAL COMPONENTS

<p>Strengthening profile S01, S02, S03L, S04, S05 (14x50 mm)</p> <p>L.: 3,00m</p>
--

<p>Large fastening plate (41x85)</p>

ATTENTION!

Remove protective film from aluminium elements (handles, tracks, connectors, etc.) prior to cutting them to the desired size. Film removal will reveal quality issues (eg. scratches)



ABC of assembly for frame profiles

Frame profile	Maximum front dimensions h * d (mm)
S01	2400 x 600
S02	2800 x 600
S03L	2800 x 600
S04	2800 x 600
S05	2800 x 600
S06	2100 x 600

Attention!

For fronts greater than standard size of 1200 x 600 it is necessary to strengthen the frame with midrail for frames S01 and S05 or strengthening profile for frames S01, S02, S03L, S04 i S05

Recommended number of hinges depends on front height and is:

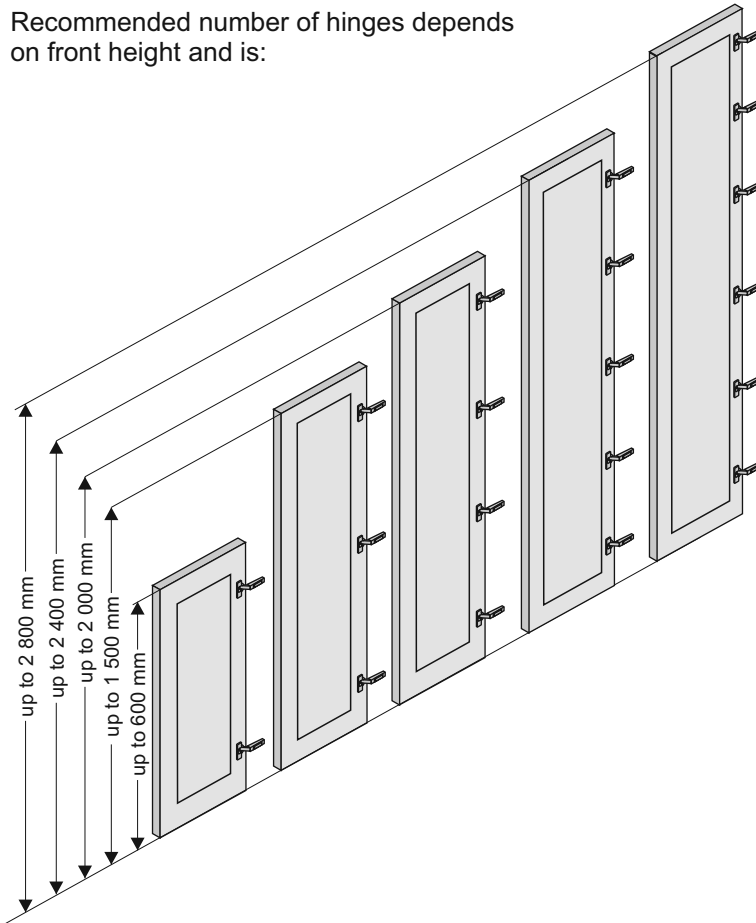

Assembly dimensions for Sevroll hinges

opening for furniture hinge

S02,
S03L,
S04,
S05

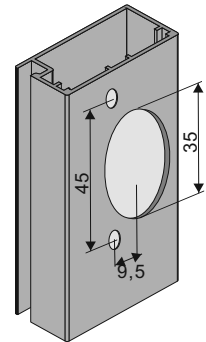

opening for clip on hinge 3D for aluminium frames

S01

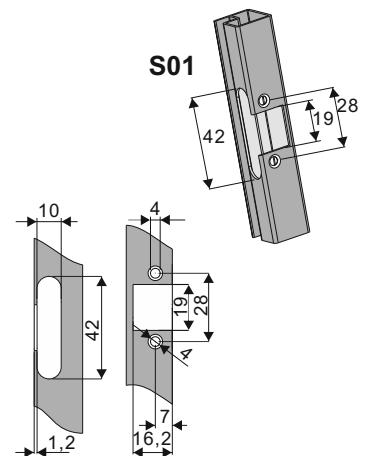

Openings for joiner S01

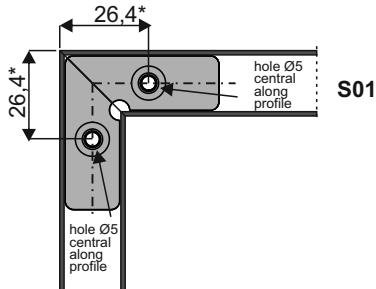

Openings for joiner S02, S03L, S04, S05

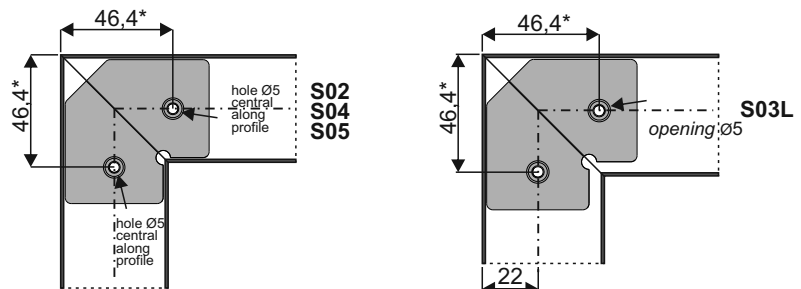

Chamfer the holes for the M5 screw.

Dimensions are for guidance only. To produce tighter corners, dimensions marked with * can be increased by up to 0.5 mm