

Maximum load for slides: 35 kg
Slide lengths: 250, 300, 350, 400, 450, 500, 550, 600 mm

Height adjustment: 0 to 2 mm
Depth adjustment: 0 to 5 mm
Width adjustment: 0 to 1.5 mm

LW - internal cabinet width
SKW - internal drawer width

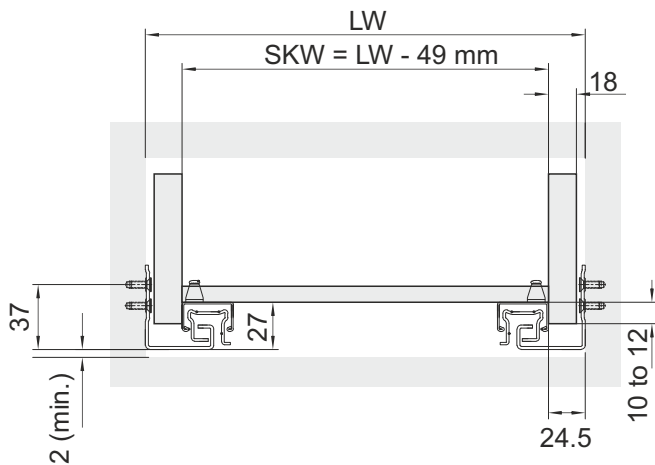

NL - nominal length of slide
LT - internal cabin depth
Drawer side thickness: 18 mm

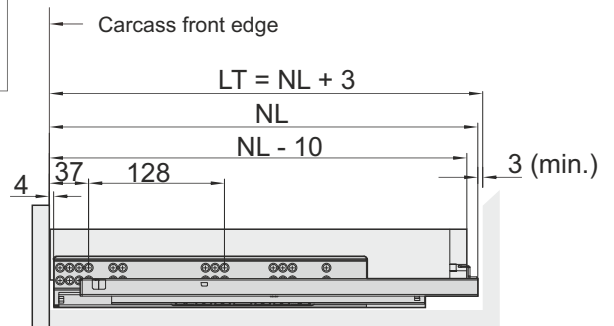

drawer with overlay front

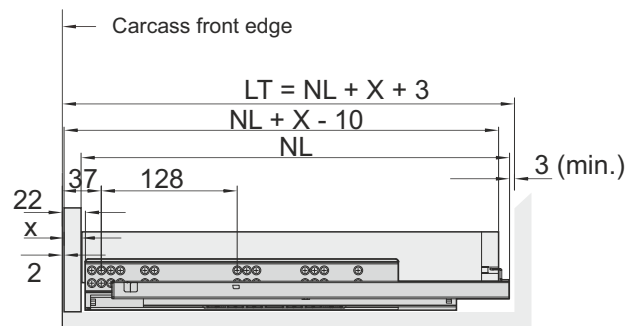

drawer with inset front

Drawer runner positioning

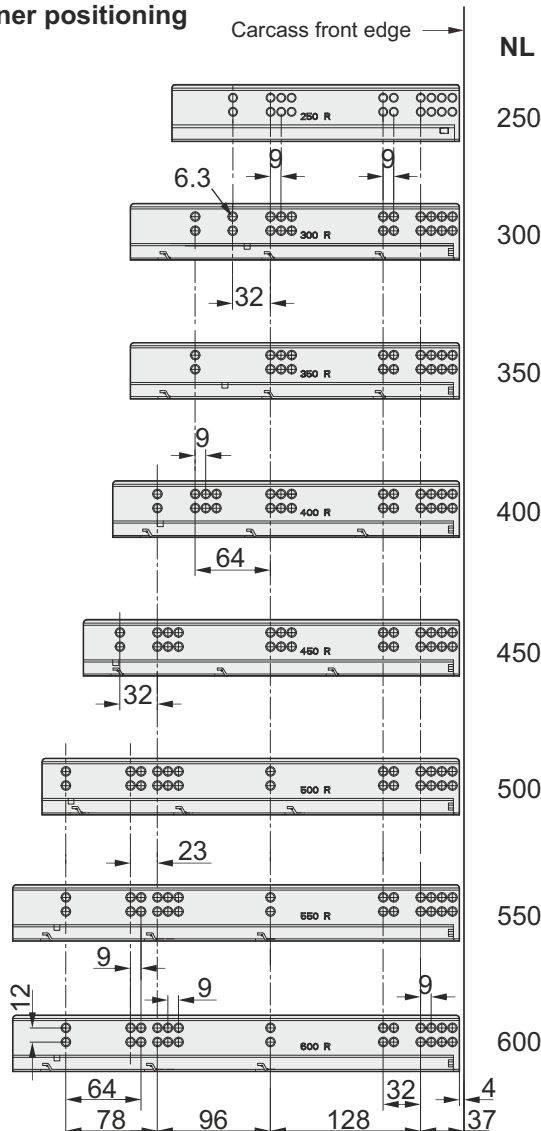

Slide length

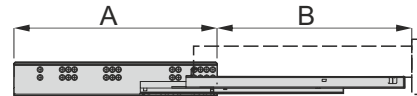

NL	250	300	350	400	450	500	550	600
A	250	280	280	295	320	355	380	380
B	200	270	320	370	420	470	520	570

Mounting dimensions for drawers

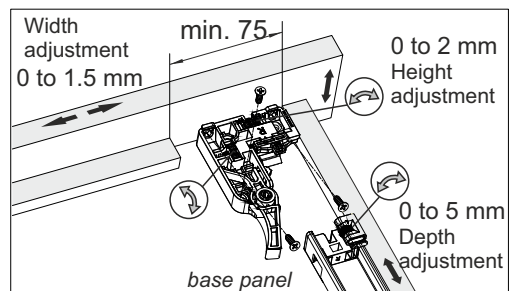
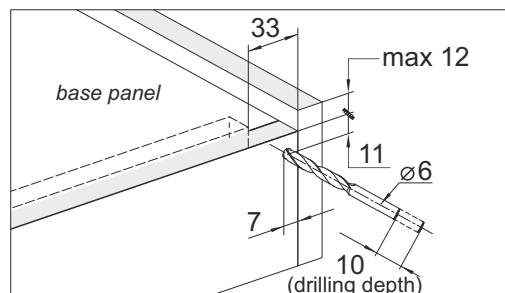

To quickly and accurately drill the holes in the back of the drawers we recommended using our drilling jig for drawers with undermounting slides (Code 20415)